

FED SUP CLASS
5306

AN101301
THRU
AN101400

MATERIAL IDENTIFICATION PER
AMS260C RAISED OR DEPRESSED
.010 MAX

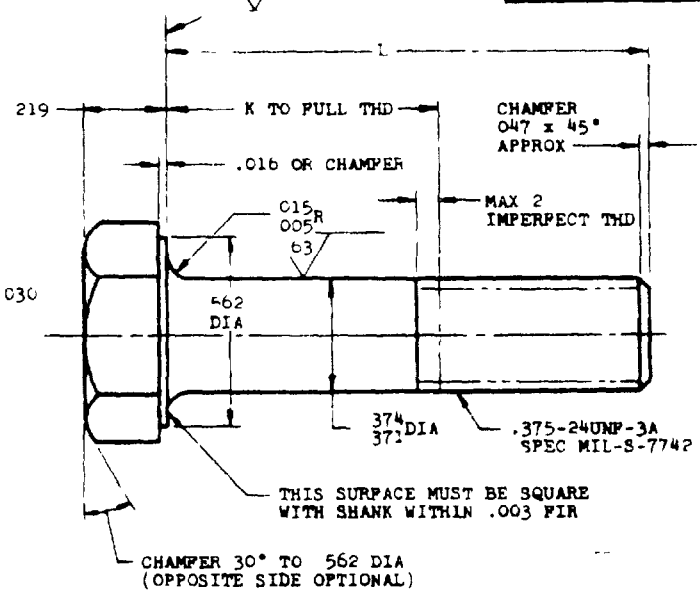
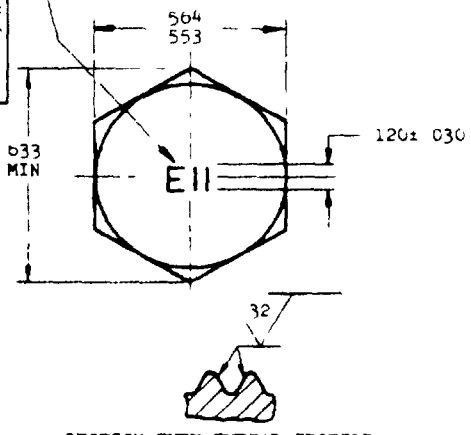

SECTION THRU THREAD PROFILE

L	K + .000 - .060	PART NO	L	K + .000 - .060	PART NO	L	K + .000 - .060	PART NO	L	K + .000 - .060	PART NO
750	(a)	AN101306	1 500	750	AN101318	3 000	2 250	AN101332	4 750	4 000	AN101346
			1 562	812	AN101319	3 125	2 312	AN101333	4 875	4 125	AN101347
			1 625	875	AN101320	3 250	2 500	AN101334	5 000	4 250	AN101348
812	(a)	AN101307	1 688	938	AN101321	3 375	2 625	AN101335	5 125	4 375	AN101349
875	125	AN101308	1 750	1 000	AN101322	3 500	2 750	AN101336	5 250	4 500	AN101350
938	188	AN101309	1 875	1 125	AN101323	3 625	2 875	AN101337	5 375	4 625	AN101351
1 000	.250	AN101310	2 000	1 250	AN101324	3 750	3 000	AN101338	5 500	4 750	AN101352
1 062	312	AN101311	2 125	1 375	AN101325	3 875	3 125	AN101339	5 625	4 875	AN101353
1 125	375	AN101312	2 250	1 500	AN101326	4 000	3 250	AN101340	5 750	5 000	AN101354
1 188	438	AN101313	2 375	1 625	AN101327	4 125	3 375	AN101341	5 875	5 125	AN101355
1 250	500	AN101314	2 500	1 750	AN101328	4 250	3 500	AN101342	6 000	5 250	AN101356
1 312	562	AN101315	2 625	1 875	AN101329	4 375	3 625	AN101343			
1 375	625	AN101316	2 750	2 000	AN101330	4 500	3 750	AN101344			
1 438	688	AN101317	2 875	2 125	AN101331	4 625	3 875	AN101345			

(a) THREAD TO HEAD MAXIMUM TWO IMPERFECT THREADS

- NOTE (1) SHANK SHALL BE STRAIGHT WITHIN .0025 FIR PER INCH OF BOLT LENGTH
 (2) THE CONCENTRICITY OF THREAD PD IN RELATION TO THE SHANK SHALL BE WITHIN .006 FIR
 (3) THE CONCENTRICITY OF THE SHANK IN RELATION TO THE WASHER FACE DIAMETER AND HEXAGON SHALL BE WITHIN .017 FIR

MATERIAL STEEL AMS6322

HARDNESS ROCKWELL C26-32

FINISH CADMIUM PLATE AMS2407

SURFACE ROUGHNESS AS.107

MANUFACTURING SPECIFICATION AMS7452

① INSPECTION ALL PARTS SHALL UNDERGO MAGNETIC INSPECTION IN ACCORDANCE WITH AMS2640
 BREAK SHARP EDGES .003- .015 UNLESS OTHERWISE SPECIFIED

DIMENSIONS IN INCHES UNLESS OTHERWISE SPECIFIED TOLERANCES, LINEAR DIMENSIONS ± .010, ANGULAR DIMENSIONS ± 2°

DO NOT USE UNASSIGNED PART NUMBERS

INACTIVE FOR NEW DESIGN AFTER 3 MARCH 1969 NO SUPERSEDING STANDARD

THIS STANDARD WAS DEVELOPED COOPERATIVELY BY THE ENGINE AND PROPELLER UTILITY PARTS COMMITTEE OF THE SAE

PA AF-11
CUST NAVY-AS
ARMY-AV

AIR FORCE-NAVY AERONAUTICAL STANDARD

BOLT - HEX HEAD 375-24

AN101301
THRU
AN101400

DISTRIBUTION STATEMENT A Approved for public release, distribution is unlimited

NOTICE When Government drawings, specifications, or other data are used for any purpose other than in connection with a definitely related Government procurement contract, the Government assumes no responsibility for any drawings, specifications, or other data that may be reproduced or transmitted in any form or by any means, including photocopying and recording, or by any information storage and retrieval system, without the prior written permission of the Government.

APPROVED 8 JUN 69 REVISED 1 31 AUG 54 3 MAR 69 30 JUNE 1986