

AN101601
THRU
AN101700

MATERIAL IDENTIFICATION PER
AMS2800. RAISED OR DEPRESSED
.010 MAX

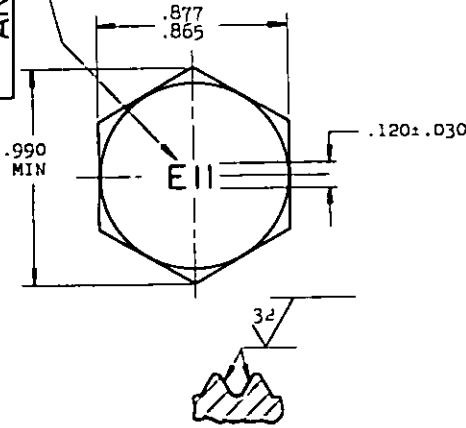

SECTION THRU THREAD PROFILE

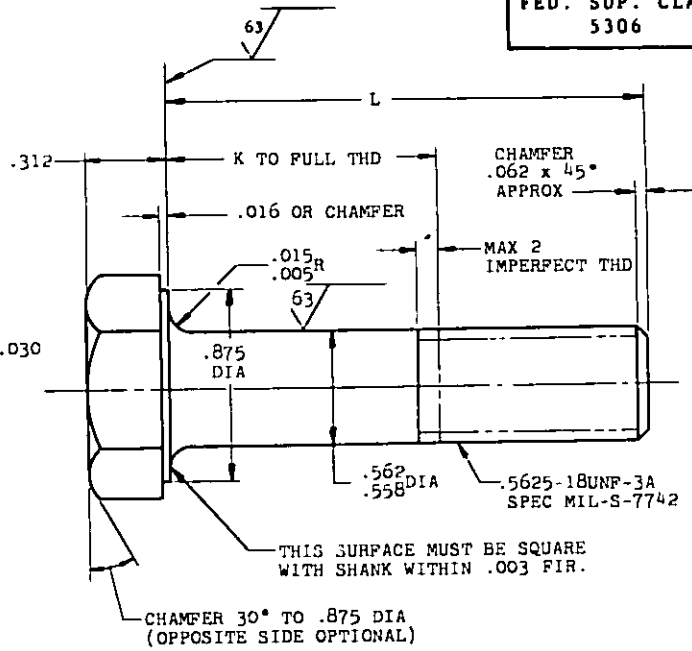

L	K +.000 -.060	PART NO.	L	K +.000 -.060	PART NO.	L	K +.000 -.060	PART NO.	L	K +.000 -.060	PART NO.
			1.750	.812	AN101617	3.375	2.438	AN101631	5.125	4.188	AN101645
			1.812	.875	AN101618	3.500	2.562	AN101632	5.250	4.312	AN101646
			1.875	.938	AN101619	3.625	2.688	AN101633	5.375	4.438	AN101647
1.062	.125	AN101606	2.000	1.062	AN101620	3.750	2.812	AN101634	5.500	4.562	AN101648
1.125	.188	AN101607	2.125	1.188	AN101621	3.875	2.938	AN101635	5.625	4.688	AN101649
1.188	.250	AN101608	2.250	1.312	AN101622	4.000	3.062	AN101636	5.750	4.812	AN101650
1.250	.312	AN101609	2.375	1.438	AN101623	4.125	3.188	AN101637	5.875	4.938	AN101651
1.312	.375	AN101610	2.500	1.562	AN101624	4.250	3.312	AN101638	6.000	5.062	AN101652
1.375	.438	AN101611	2.625	1.688	AN101625	4.375	3.438	AN101639			
1.438	.500	AN101612	2.750	1.812	AN101626	4.500	3.562	AN101640			
1.500	.562	AN101613	2.875	1.938	AN101627	4.625	3.688	AN101641			
1.562	.625	AN101614	3.000	2.062	AN101628	4.750	3.812	AN101642			
1.625	.688	AN101615	3.125	2.188	AN101629	4.875	3.938	AN101643			
1.688	.750	AN101616	3.250	2.312	AN101630	5.000	4.062	AN101644			

- NOTE: (1) SHANK SHALL BE STRAIGHT WITHIN .002 FIR. PER INCH OF BOLT LENGTH.
 (2) THE CONCENTRICITY OF THREAD PD IN RELATION TO THE SHANK SHALL BE WITHIN .006 FIR.
 (3) THE CONCENTRICITY OF THE SHANK IN RELATION TO THE WASHER FACE DIAMETER AND HEXAGON SHALL BE WITHIN .026 FIR.

MATERIAL: STEEL AMS6322

HARDNESS: ROCKWELL C26-32

FINISH: CADMIUM PLATE AMS2400

SURFACE ROUGHNESS: AS107

MANUFACTURING SPECIFICATION: AMS7452

- (3) INSPECTION: ALL PARTS SHALL UNDERGO MAGNETIC INSPECTION IN ACCORDANCE WITH AMS2640.
 BREAK SHARP EDGES .003-.015 UNLESS OTHERWISE SPECIFIED.

DIMENSIONS IN INCHES. UNLESS OTHERWISE SPECIFIED: TOLERANCES; LINEAR DIMENSIONS ±.010, ANGULAR DIMENSIONS ±2°.

DO NOT USE UNASSIGNED PART NUMBERS.

(2) INACTIVE FOR NEW DESIGN AFTER 3 MARCH 1969 NO SUPERSEDING STANDARD.

THIS STANDARD WAS DEVELOPED COOPERATIVELY BY THE ENGINE AND PROPELLER UTILITY PARTS COMMITTEE OF THE SAE.

P.A. AF-11
CUST. NAVY-AS
ARMY-AV

AIR FORCE-NAVY AERONAUTICAL STANDARD

BOLT - HEX HEAD .5625-18

AN101601
THRU
AN101700

NOTICE: When Government drawings, specifications, or other data are used for any purpose other than in connection with a definitely related Government procurement operation, the United States Government thereby incurs no responsibility, nor any obligation whatsoever; and the fact that the Government may have furnished, furnished, or in any way supplied the said drawings, specifications, or other data is not to be interpreted by implication or otherwise as in any manner benefiting the holder or any other person or corporation, or conveying any rights or permission to manufacture, use, or sell any product or invention that may in any way be related thereto.

DISTRIBUTION STATEMENT A. Approved for public release; distribution is unlimited.

APPROVED Jun 4, 1969 REVISED 31 Aug 61, 3 Mar 69 30 June 1986