

NOTE: This drawing was approved by joint action of the Air Force and Navy Departments as the Air Force Navy standard for this product. This drawing supersedes all previous standard drawings for the same product and shall become effective for the procurement of aeronautical supplies, or for use in new designs, on their date of release after the latest date of approval shown.

7. When Government drawings, specifications or other data are used for any purpose other than in connection with a specific Federal operation, the United States Government thereby incurs no responsibility nor any obligation whatsoever; and the Government may have terminated the original contract, or in any way supplied the said drawings, specifications, or other data, or may in any manner retransmit, or otherwise use, or authorize the use of, in any manner, or for any other purpose or purposes, or exercising any rights or permissions in manufacture, use, or sale, or any part thereof, that may in any way be related thereto.

NAVY 1002A (REV. 1-51)

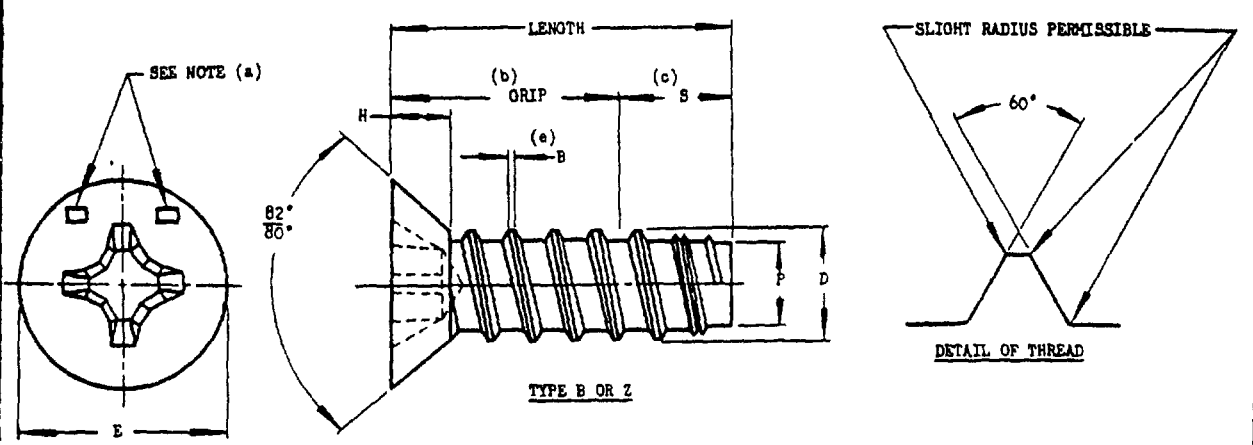

⑤ DESIGN I RECESSED HEAD, THREAD FORMING SCREW

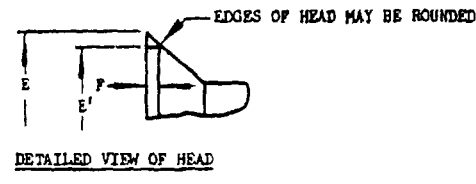

DETAILED VIEW OF HEAD

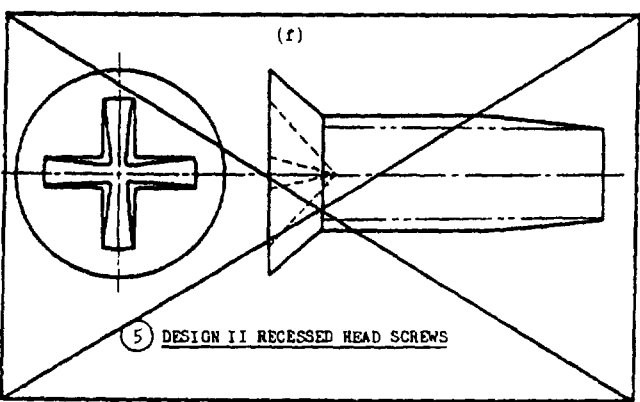

⑤ DESIGN II RECESSED HEAD SCREWS

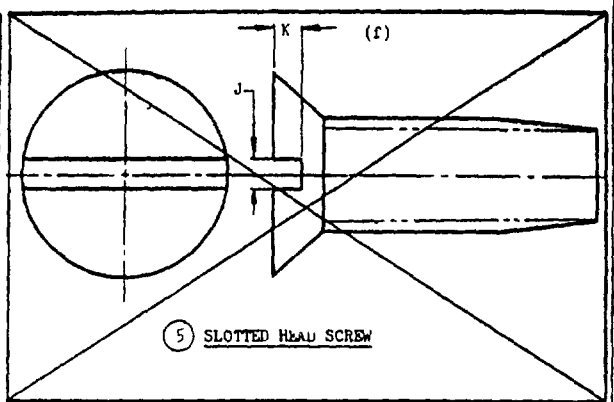

⑤ SLOTTED HEAD SCREW

⑤ DIMENSIONING AND GAGING OF THE ABOVE RECESS DESIGNS SHALL BE IN ACCORDANCE WITH FF-S-92.

SIZE	THREADS PER INCH	D MAX DIA	E DIA		E' DIA	F MAX	H		J		K		P DIA	
			MAX SHARP	MIN SHARP	ABSOLUTE MIN WITH MAX F		MAX	MIN	MAX	MIN	MAX	MIN		
NO. 4	2L	.114	.225	.207	.200	.016	.067	.055	.039	.031	.030	.020	.079	.074
NO. 6	20	.139	.279	.257	.249	.019	.083	.069	.046	.039	.036	.024	.095	.089
NO. 8	18	.166	.332	.308	.300	.022	.100	.084	.064	.045	.045	.029	.112	.106
NO. 10	16	.189	.385	.359	.348	.025	.116	.098	.060	.050	.053	.034	.130	.123
1/4	14	.246	.491	.461	.447	.031	.148	.127	.075	.064	.068	.044	.179	.171

⑤ (f) DESIGN II RECESSED AND SLOTTED HEAD SCREWS INACTIVE FOR DESIGN AFTER 17 FEBRUARY 1959.

PROCUREMENT SPECIFICATION NIL-8-6033	AIR FORCE-NAVY AERONAUTICAL STANDARD	AN531
	SCREW, TAPPING, THREAD FORMING OR THREAD CUTTING, 82-DEGREE FLAT HEAD, SPACED THREAD	

SHEET 1 OF 3
SUPERSEDES USAF DRAWING 531

APPROVED 12 Feb 43 REVISED 1 25 Apr 44 2 18 Feb 46 3 29 Apr 49 4 10 Jan 55 5 17 Feb 59

When Government drawings, specifications, or other data are used for any purpose other than in connection with a definite contract with the United States Government, the United States Government hereby incurs no responsibility, nor any obligation whatsoever, and the contractor shall in no way be regarded as endorsing, or conveying any rights or permission to manufacture, use or sell any patented invention that may in any way be related thereto.

This drawing was approved by joint action of the Air Force and Navy Departments as the Air Force-Navy standard for this product. The drawing supersedes all antecedent standard drawings for the same product and shall remain effective for the procurement of aeronautical equipment, or for use in new designs, not later than 6 months after the latest date of approval thereon.

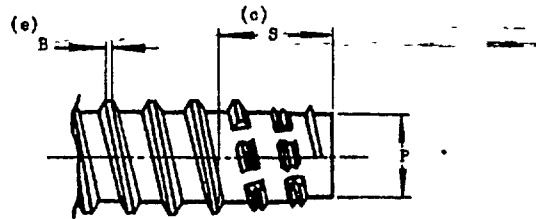

TYPE BF OR FZ

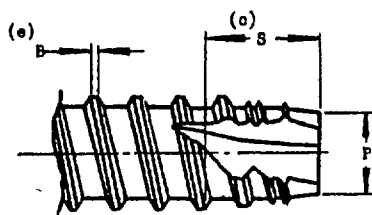

TYPE BT OR 25

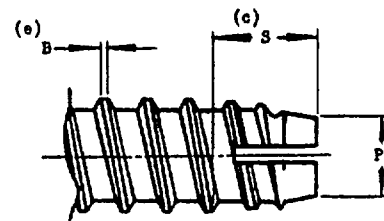

TYPE BO OR H

(d) OPTIONAL TYPES OF ENDS FOR THREAD CUTTING SCREWS

① CARBON STEEL, SLOTTED HEAD SCREWS, THREAD FORMING, DASH NUMBERS FOR:

LENGTH	NO. 4		NO. 6		NO. 8		NO. 10		1/4	
	DASH NO.	GRIP MIN	DASH NO.	GRIP MIN	DASH NO.	GRIP MIN	DASH NO.	GRIP MIN	DASH NO.	GRIP MIN
1/4		.115								
3/8	+0	.240	6-6	.219	8-6	.205				
1/2	-1/32	.365	6-8	.344	8-8	.330	10-8	.313		
5/8			6-10	.469	8-10	.455	10-10	.438	14-10	.415
3/4			6-12	.578	8-12	.564	10-12	.547	14-12	.524
7/8	+0		6-14	.703	8-14	.689	10-14	.672	14-14	.649
1	-3/64		6-16	.828	8-16	.814	10-16	.797	14-16	.774
1 1/4			6-20	1.078	8-20	1.203	10-20	1.047	14-20	1.024
1 1/2			6-24	1.328	8-24	1.314	10-24	1.297	14-24	1.274
1 3/4					8-28	1.549	10-28	1.532	14-28	1.509
2	+0				8-32	1.800	10-32	1.782	14-32	1.759
2 1/4	-1/16				8-36	2.049	10-36	2.032	14-36	2.009
2 1/2					8-40	2.300	10-40	2.282	14-40	2.259

PROCUREMENT SPECIFICATION
MIL-B-6033

AIR FORCE-NAVY AERONAUTICAL STANDARD
SCREW, TAPPING, THREAD FORMING OR THREAD CUTTING, 82-DEGREE FLAT HEAD, SPACED THREAD

AN531

SHEET 2

APPROVED 10 JAN 55 REVISED 12 JUL 55

NOTICE: This drawing was approved by joint action of the Air Force and Navy Department in accordance with the provisions of the Joint Air Force-Navy Standardization Agreement. It is the responsibility of the user to determine the applicability of this drawing to his own product. The user shall be responsible for any change in the drawing and for any error in the drawing. The user shall be responsible for any change in the drawing and for any error in the drawing. The user shall be responsible for any change in the drawing and for any error in the drawing.

This drawing was approved by joint action of the Air Force and Navy Department in accordance with the provisions of the Joint Air Force-Navy Standardization Agreement. It is the responsibility of the user to determine the applicability of this drawing to his own product. The user shall be responsible for any change in the drawing and for any error in the drawing. The user shall be responsible for any change in the drawing and for any error in the drawing. The user shall be responsible for any change in the drawing and for any error in the drawing.

- (a) MARKING FOR CORROSION-RESISTANT STEEL SCREWS. ONLY ONE DASH NEED BE VISIBLE, POSITION OPTIONAL. NO MARKING REQUIRED ON HEADS OF NO. 4 SCREWS.
- (b) THE GRIP LENGTH IS MEASURED FROM THE TOP OF THE HEAD TO THE END OF THE FULL-THREADED PORTION OF THE SHANK. THE MINIMUM GRIP DIMENSIONS SHOWN IN THE DASH NUMBER TABLE ARE FOR DESIGN PURPOSES ONLY AND ARE NOT AN INSPECTION REQUIREMENT.
- (c) TAPER LENGTH, S, IS 2 TO 2-1/2 TIMES THE PITCH OF THE THREAD.
- (d) SCREWS DESIGNATED AS THREAD FORMING HAVE PLAIN ENDS (NOT FLUTED OR SLOTTED). SCREWS DESIGNATED AS THREAD CUTTING HAVE FLUTED OR SLOTTED ENDS.
- (e) MAXIMUM CREST OF THREAD, B, UP TO AND INCLUDING SIZE NO. 8 EQUALS 0.004 INCH; MAXIMUM CREST OF THREAD OVER SIZE NO. 8 EQUALS 0.006 INCH. TAPERED THREADS HAVE UNFINISHED CRESTS.

- ① MATERIAL: CARBON STEEL, CASE HARDENED, OR CORROSION-RESISTANT STEEL, TYPE 410, HARDENED.
- ① FINISH: CARBON STEEL, CADMIUM PLATE, SPECIFICATION QQ-P-416, TYPE I, CLASS C. CORROSION-RESISTANT STEEL, NONE.

ADD C BEFORE FIRST DASH NUMBER FOR CORROSION-RESISTANT STEEL SCREWS.

ADD F BETWEEN FIRST AND SECOND DASH NUMBERS FOR SCREWS WITH FLUTED OR SLOTTED ENDS, (THREAD CUTTING). IF R APPEARS IN THE CODING, ADD THE F IMMEDIATELY FOLLOWING THE R.

ADD R BETWEEN FIRST AND SECOND DASH NUMBERS FOR RECESSED HEAD SCREWS.

- ① EXAMPLES OF PART NUMBERS:
 - AN531-6-8 - NO. 6, CARBON STEEL, SLOTTED HEAD, THREAD FORMING SCREW, 8/16 IN LENGTH.
 - AN531-6R8 - NO. 6, CARBON STEEL, RECESSED HEAD, THREAD FORMING SCREW, 8/16 IN LENGTH.
 - AN531-6RFB - NO. 6, CARBON STEEL, RECESSED HEAD, FLUTED OR THREAD CUTTING SCREW, 8/16 IN LENGTH.
 - AN531C6-F - NO. 6, CORROSION-RESISTANT STEEL, SLOTTED HEAD, THREAD FORMING SCREW, 8/16 IN LENGTH.
 - AN531C6R8 - NO. 6, CORROSION-RESISTANT STEEL, RECESSED HEAD, THREAD FORMING SCREW, 8/16 IN LENGTH.
 - AN531C6RFB - NO. 6, CORROSION-RESISTANT STEEL, RECESSED HEAD, FLUTED OR THREAD CUTTING SCREW, 8/16 IN LENGTH.

SCREWS HAVING FIVE THREADS OR LESS MAY HAVE FINER PITCH THREADS, OR SHORTER POINTS, OR FINER PITCH THREADS AND SHORTER POINTS, AT THE OPTION OF THE PRODUCER.

SCREW MANUFACTURER'S DESIGNATION MAY BE INCLUDED ON THE SCREWS.

SCREWS SHALL BE FREE OF ALL LOOSE OR HANGING BURRS OR SLIVERS WHICH MIGHT BECOME DISLODGED UNDER USAGE.

DIMENSIONS IN INCHES.

SUBJECT TO AND10087 LIMITATIONS, THE THREAD FORMING SCREWS SHOWN ON THIS DRAWING MAY BE USED WITH SPECIFICATION MIL-N-3337 SHEET SPACING NUTS.

SUBJECT TO AND10087 LIMITATIONS, THE SCREWS MAY BE USED AS TAPPING SCREWS WITH AND10325 HOLE SIZES AND AND10387 HOLE TOLERANCES.

APPROVED 10 Jan 55 REVISED ① 12 Jul 55

PROCUREMENT SPECIFICATION MIL-S-6033	AIR FORCE-NAVY AERONAUTICAL STANDARD	AN531 SHEET 3
	SCREW, TAPPING, THREAD FORMING OR THREAD CUTTING, 82-DEGREE FLAT HEAD, SPACED THREAD	

INCH-POUND

AN531 REV. 5
AMENDMENT 1
20 May 1996

AIR FORCE - NAVY AERONAUTICAL STANDARD

SCREW, TAPPING, THREAD FORMING OR THREAD
CUTTING, 82 DEGREE, FLAT HEAD, SPACED THREAD

This amendment forms a part of AN531 REV. 5, dated , 17 February 1959 and is approved for use by all Departments and Agencies of the Department of Defense.

PAGES 1, 2 and 3

In Procurement Specification Block delete: "MIL-S-6033" and substitute: "FF-S-107".

PAGE 3

The fifth and sixth sentences under part number examples "Subject to AND10087 limitations...." delete: "AND10087" and substitute: "MS33749".

Custodians:

Navy - AS
Air Force - 99

Preparing Activity:
DLA-IS

(Project 5305-2133)

AMSC N/A

FSC 5405

DISTRIBUTION STATEMENT A Approved for public release, distribution is unlimited