

REVIEWER SYMBOLS: USER SYMBOLS:
ARMY - AV, EL, AT, ME, WC

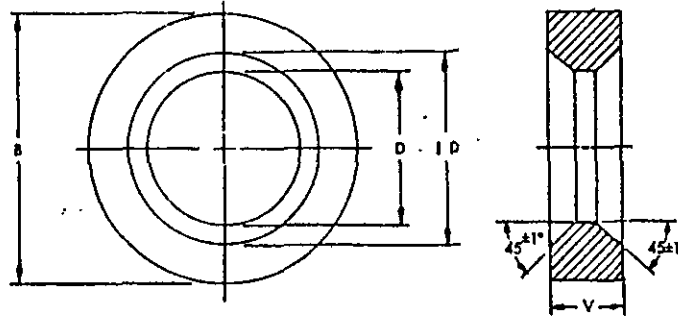

"Review/user information is current as of the date of this document. For future coordination of changes to this document, draft circulation should be based on the information in the current DODISS."

DASH NO.	NOMINAL SIZE	B		D		ID		V		FLATNESS MAX	APPROX WEIGHT LB/100
		MAX	MIN	MAX	MIN	MAX	MIN	MAX	MIN		
4	1/4	.505	.495	.255	.251	.347	.337	.124	.114	.007	.47
5	5/16	.620	.610	.318	.314	.409	.399	.124	.114		.71
6	3/8	.766	.756	.380	.376	.504	.494	.158	.144		1.47
7	7/16	.878	.868	.443	.439	.566	.556	.158	.144		1.89
8	1/2	1.004	.994	.505	.501	.629	.619	.163	.149	.010	2.49
9	9/16	1.120	1.110	.568	.564	.691	.681	.195	.181		4.51
10	5/8	1.266	1.256	.631	.627	.785	.775	.226	.212		5.87
12	3/4	1.507	1.497	.756	.752	.910	.900	.278	.264		9.85
14	7/8	1.747	1.737	.881	.877	1.035	1.025	.320	.306		15.37
16	1	1.978	1.968	1.006	1.002	1.160	1.150	.368	.354		22.74

MATERIAL: ALLOY STEEL, MIL-S-6758, MIL-S-18729.

HARDNESS: ROCKWELL C 39-43.

SURFACE TEXTURE: 125/ IN ACCORDANCE WITH ANSI B46.1.

PLATING: CADMIUM PLATE, QQ-P-416, TYPE II, CLASS 2.

PARALLELISM: WASHER FACES SHALL BE PARALLEL WITHIN 0.002 INCH.

WASHER SHALL BE FREE FROM ALL HANGING BURRS AND SLIVERS WHICH MIGHT BECOME DISLODGED UNDER USAGE.

DIMENSIONS IN INCHES.

DESIGN AND USAGE INFORMATION: THESE WASHERS ARE PRIMARILY FOR USE WITH MS 14156 NUTS AND MS 14157 BOLTS.

FOR DESIGN FEATURE PURPOSES, THIS STANDARD TAKES PRECEDENCE OVER DOCUMENTS REFERENCED HEREIN.

REFERENCE SHALL BE THE ISSUE IN EFFECT ON DATE OF INVITATION FOR BID.

EXAMPLE OF PART NUMBERS: MS14155-4 WASHER, COUNTERSUNK TWO SURFACES, FOR 1/4 THREAD SIZE, 180 KSI BOLT.

This military standard is approved for use by all Departments & Agencies of the Department of Defense. Selection for all new engineering and design applications and for reengineering shall be made from this document.

P.A.
NAVY - AS
Other Code
USAF - 11
ARMY - AV

TITLE
WASHER, RECESSED COUNTERSUNK TWO SURFACES, FOR USE WITH WHEEL BOLTS AND NUTS UP TO AND INCLUDING 180 KSI Fcu

MILITARY STANDARD
MS14155
SHEET 1 OF 1

PROCUREMENT SPECIFICATION SUPERSEDES:

STANDARDIZATION DOCUMENT IMPROVEMENT PROPOSAL

OMB Approval
No. 22-R255

INSTRUCTIONS: The purpose of this form is to solicit beneficial comments which will help achieve procurement of suitable products at reasonable cost and minimum delay, or will otherwise enhance use of the document. DoD contractors, government activities, or manufacturers/vendors who are prospective suppliers of the product are invited to submit comments to the government. Fold on lines on reverse side, staple in corner, and send to preparing activity. Comments submitted on this form do not constitute or imply authorization to waive any portion of the referenced document(s) or to amend contractual requirements. Attach any pertinent data which may be of use in improving this document. If there are additional papers, attach to form and place both in an envelope addressed to preparing activity.

DOCUMENT IDENTIFIER AND TITLE MS14155 WASHER, RECESSED COUNTERSUNK TWO SURFACES, FOR USE WITH WHEEL BOLTS AND NUTS UP TO AND INCLUDING 180 KSI Ft_u

NAME OF ORGANIZATION AND ADDRESS

CONTRACT NUMBER

MATERIAL PROCURED UNDER A

DIRECT GOVERNMENT CONTRACT SUBCONTRACT

1. HAS ANY PART OF THE DOCUMENT CREATED PROBLEMS OR REQUIRED INTERPRETATION IN PROCUREMENT USE?

A. GIVE PARAGRAPH NUMBER AND WORDING.

B. RECOMMENDATIONS FOR CORRECTING THE DEFICIENCIES

2. COMMENTS ON ANY DOCUMENT REQUIREMENT CONSIDERED TOO RIGID

3. IS THE DOCUMENT RESTRICTIVE?

YES NO (If "Yes", in what way?)

4. REMARKS

SUBMITTED BY (Printed or typed name and address - Optional)

TELEPHONE NO.

DATE

FOLD

DEPARTMENT OF THE NAVY
Naval Air Engineering Center
Philadelphia, PA 19112

OFFICIAL BUSINESS

POSTAGE AND FEES PAID
DEPARTMENT OF THE NAVY
DOD 316



Engineering Specifications and Standards Department (Code ES)
Naval Air Engineering Center
Philadelphia, PA 19112

FOLD