

REVIEWER SYMBOLS: USAF-II USER SYMBOLS:
ARMY-AR
DLA - 15

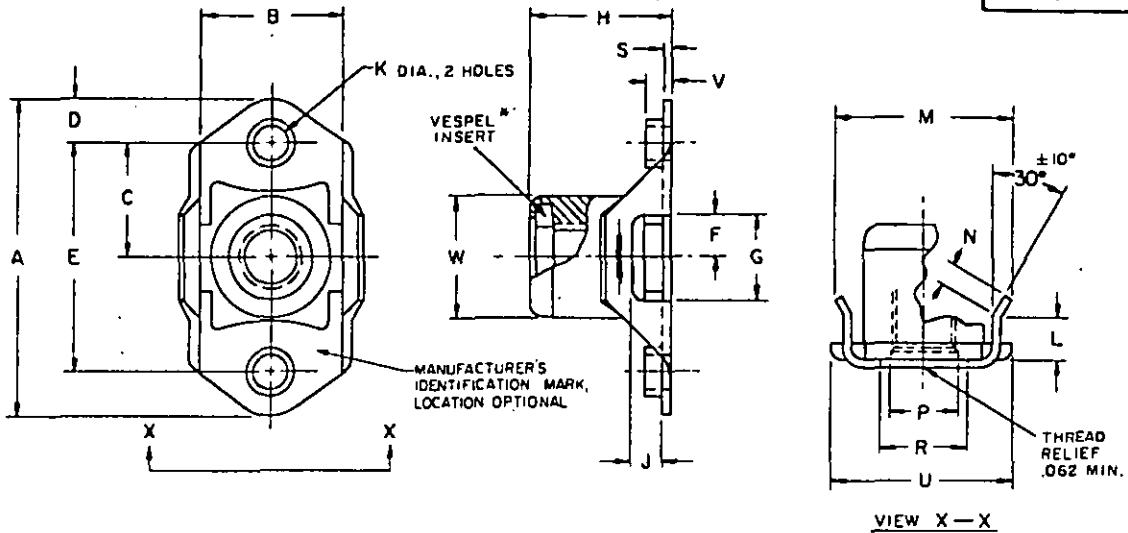

* Reviewer/User information is current as of the date of this document. For future coordination of changes in this document, draft circulation should be based on the information in the current DODISS.

This military standard is approved for use by all Departments and Agencies of the Department of Defense. Selection for this standard is based on design applications and for repetitive use shall be made from this document.

PART NUMBER	THREAD SIZE (a)	A	B	C	D	E	F	G	H (b)	J	K	L	M	N	P	R	S	U
		MAX	±.005	±.005	MIN	±.002	±.010	±.010	MAX	±.000 -.015	±.005 -.000	REF.	MAX.	REF.	MIN	MAX.	±.006	±.000 -.006
MS14179-3	.1900-32UNJF-3B	.739	.430	.250	.100	.500	.125	.250	.370	.093	.098	.125	.550	.062	.194	.250	.030	.540
MS14179-4	.2500-28UNJF-3B	.801	.488	.281	.100	.562	.140	.280	.457	.105	.098	.140	.630	.070	.254	.310	.030	.600
MS14179-5	.3125-24UNJF-3B	1.010	.560	.359	.117	.718	.155	.310	.540	.113	.130	.155	.730	.075	.317	.375	.040	.678

V (A)	W	"X"	AXIAL TENSILE STRENGTH LBS. MIN.	SEATING TORQUE IN LBS.	PUSH-OUT LBS. MIN.	TORQUE-OUT IN LBS. MIN.	WEIGHT LBS/100	
								MAX
.125	.075	.370	.005	3,620	40	200	90	.75
.140	.090	.440	.006	6,470	70	250	190	1.25
.160	.110	.500	.007	10,200	140	250	240	1.90

(a) THREADS BEFORE LUBRICATION PER MIL-S-8879
(b) MINIMUM "H" NOT SPECIFIED. LIMITED ONLY BY STRENGTH REQUIREMENTS. BOLT THREAD ENGAGEMENT SHALL BE CHECKED FOR PROPER PROTRUSION.

NOTES:

- MATERIAL: NUT ELEMENT - CARBON STEEL PER AISI C1035, AISI C1042, AISI C1050, AISI C11137 OR ALLOY STEEL PER AMS 6322, AMS 6415, AMS 6304.
BASKET - CARBON STEEL PER AISI C1035, AISI C1050
INSERT: VESPEL* POLYIMIDE
*DUPONT REGISTERED TRADEMARK
- HARDNESS: ROCKWELL "C" 46 MAXIMUM
- PLATING: CADMIUM PLATE IN ACCORDANCE WITH QQ-P-416, TYPE II, CLASS 2.
- LUBRICANT: NUT ELEMENT - DRY FILM LUBRICANT, (SUPPLEMENTARY LUBRICANT OPTIONAL).
- FLOAT: MIN. RADIAL .020. NUT SHALL BE CAPABLE OF ENGAGEMENT WITH BOLT IN MAXIMUM MISALIGNED POSITION.
- PERFORMANCE: MIL-N-8985 EXCEPT AS FOLLOWS:
 - SEVEN NUTS SHALL BE ASSEMBLED ON THE BOLTS. IMMERSIVE FIRST NUT AND BOLT ASSEMBLY IN MIL-H-5606 FLUID; SECOND NUT AND BOLT ASSEMBLY IN MIL-T-2624 FLUID; THIRD ASSEMBLY IN MIL-L-7808 FLUID; FOURTH ASSEMBLY IN MIL-A-8243 FLUID; FIFTH ASSEMBLY IN MIL-C-43616 FLUID; SIXTH ASSEMBLY IN MIL-H-83283 FLUID; SEVENTH ASSEMBLY IN SKYDROL 500B FLUID FOR 24 HOURS AT 160°F. AFTER 12 HOURS DRYING IN AIR THE NUTS SHALL BE REMOVED AND REINSTALLED (SEATED) ON THE BOLTS TO THE SEATING TORQUE VALUES TABULATED ABOVE FOR 500 CYCLES. THE NUTS SHALL MEET MAX. LOCKING TORQUE AND MIN. BREAKAWAY TORQUES SPECIFIED IN MIL-N-8985 THRU 500 SEATED CYCLES.
 - THREE SAMPLES SHALL BE BAKED AT 450°F FOR 6 HOURS THEN TESTED FOR 500 SEATED CYCLES AS ABOVE IN TORQUE EFFECTIVITY "a" EXCEPT FOR THIS TEST SAMPLES ARE NOT REQUIRED TO BE IMMERSIVE IN FLUIDS. THE NUTS SHALL MEET MAX. LOCKING TORQUE AND 50% OF THE MIN. BREAKAWAY TORQUES SPECIFIED IN MIL-N-8985 THRU 500 SEATED CYCLES.
 - PUSH-OUT PER MIL-N-25027 EXCEPT THE PUSH-OUT LOAD VALUES AS TABULATED ABOVE.
 - TORQUE-OUT PER MIL-N-25027 EXCEPT THE TORQUE-OUT VALUES AS TABULATED ABOVE.
 - MIN. VIBRATION LIFE SHALL BE 90,000 CYCLES.
 - WRENCH TORQUE NOT APPLICABLE.
 - MIN. AXIAL TENSILE STRENGTH VALUES AS TABULATED ABOVE.
- SURFACE TEXTURE IN ACCORDANCE WITH ANSI B46.1 SHALL NOT EXCEED 125 MICRO INCHES.
- BREAK ALL SHARP EDGES AND REMOVE ALL BURRS AND SLIVERS.
- DIMENSIONS IN INCHES.
- TOLERANCES: DECIMALS ±.010, ANGLES ±5°.
- NUT REPLACEABILITY: NUT SHALL BE REMOVABLE FROM THE BASKET WITH A TOOL OR A SCREW DRIVER AND A NEW NUT PER MS14180 SHALL BE CAPABLE OF BEING SNAPPED IN PLACE IN THE BASKET.
- BEARING SURFACE OF NUT ELEMENT AND P.D. OF THREAD SHALL RUN TRUE TO EACH OTHER WITHIN "X" WHEN MEASURED IN ACCORDANCE WITH MIL-N-8985.
- THIS STANDARD TAKES PRECEDENCE OVER PROCUREMENT DOCUMENT REFERENCED HEREIN. REFERENCED DOCUMENTS SHALL BE OF THE ISSUE IN EFFECT ON DATE OF INVITATION FOR BID.

(A) DENOTES CHANGES

P.A. NAVY - AS Other Cust USAF-99 ARMY-AV	TITLE	MILITARY STANDARD
	NUT, PLATE, SELF-LOCKING, FLOATING, TWO LUG, REDUCED RIVET SPACING, STEEL, (VESPEL* INSERT) 500 CYCLES REUSE, REPLACEABLE NUT, 160 KSI F _{tu} , 450°F.	MS 14179
PROCUREMENT SPECIFICATION: MIL-N-8985	SUPERSEDES	SHEET 1 OF 1

APPROVED 30 JAN 1979 REVISED A 30 SE T R3