

This standard has been approved by the Naval Ship Engineering Center, Department of the Navy, and is mandatory for use by that activity. All other military activities are required to employ this standard where suitable.

FED. SUP. CLASS
5305

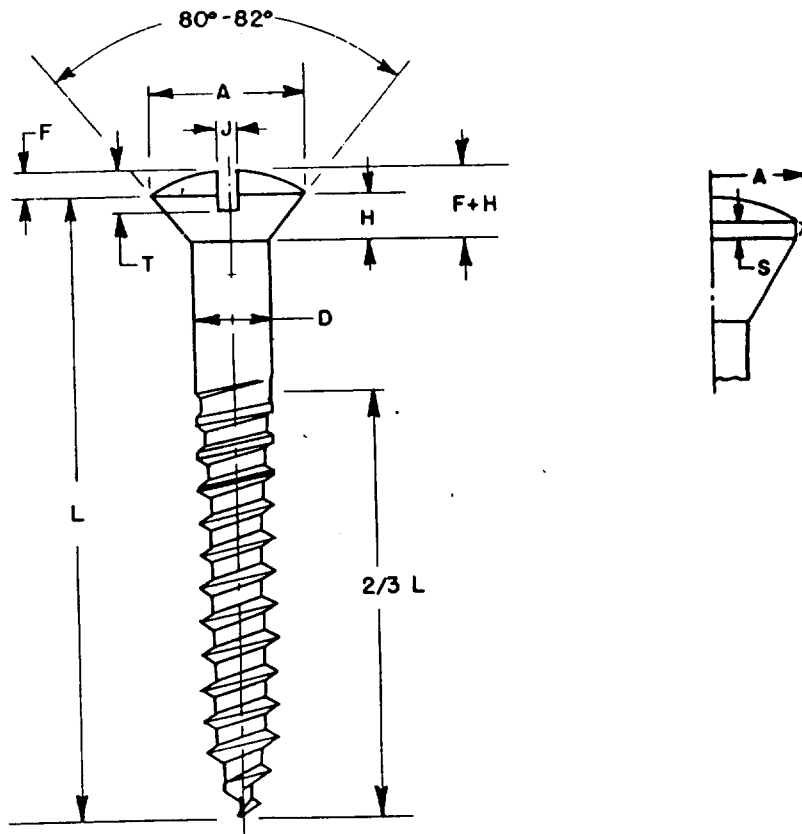

(Project 5305-N011Sh) (A) For changes see sheets 1 and 2

CUSTODIANS Ships	OTHER INT. A - N - AF -	MILITARY STANDARD		MS 16215 (SHIPS)
		SCREWS, WOOD, SLOTTED OVAL HEAD 82°, AUSTENITIC, CORROSION RESISTING STEEL, NONMAGNETIC		
Procurement Specification (A) FF-S-111				SHEET 1 OF 2

APPROVED 8 MAY 1957 REVISED (A) 19 AUGUST 1966

This standard has been approved by the Naval Ship Engineering Center, Department of the Navy, and is mandatory for use by that activity. All other military activities are required to employ this standard where suitable.

FED. SUP. CLASS
5305

Nominal size		10	12	14	
Threads per inch		13	11	10	
(D) Basic size	+0.004 -0.007	0.190	0.216	0.242	
(A) Diameter of head	Max. sharp	.385	.438	.491	
	Min. sharp	.359	.410	.461	
	Absolute min. with flat	.340	.389	.437	
(H) Height of head	Max.	.116	.132	.148	
	Min.	.098	.112	.127	
(J) Width of slot	Max.	.060	.067	.075	
	Min.	.050	.056	.064	
(T) Depth of slot	Max.	.103	.117	.132	
	Min.	.084	.096	.108	
(F) Height of oval	Max.	.061	.069	.077	
	Min.	.050	.057	.064	
F + H	Max.	.177	.201	.225	
	Min.	.148	.169	.191	
(S) Flat on min. screw		.007	.008	.009	
(L) Length	Length tolerance	MS part No.	FIIN	MS part No.	FIIN
3/4		1		--	--
7/8		2		10	--
1	+0	3		11	19
1-1/4	-3/64	4		12	20
1-1/2		5		13	21
1-3/4		6		14	22
2	+0	7		15	23
2-1/4	-1/16	8		16	24
2-1/2		9		17	25
2-3/4		.		18	26
3	+0 -3/32	-		--	27

Material: Austenitic corrosion-resisting steel shall be in accordance with class 302, 303, 304, 305, 310 or 316 of Specification QQ-S-703 or composition FS 302, 304, 310 or 316 of Specification QQ-W-423.

Tensile strength: Tensile strength shall be 70,000 p. s. i. minimum.

Permeability: The magnetic permeability of the screws shall not exceed 2.0 (mμ) when tested with a permeability indicator in accordance with Specification MIL-I-17214.

Dimensions: All dimensions are in inches unless otherwise specified.

Thread length: Thread length shall be approximately 2/3 L.

Protective coating: Screws shall be passivated in accordance with QQ-P-35

Notes:

1. Referenced documents shall be the issue in effect on date of invitation for bids.
2. In case of conflict with any document referenced herein this standard shall govern.

CUSTODIANS	OTHER INT.	MILITARY STANDARD	MS 16215 (SHIPS)
Ships	A - N - AF -		
Procurement Specification A PF-S-111.		SCREWS, WOOD, SLOTTED OVAL HEAD 82°, AUSTENITIC, CORROSION RESISTING STEEL, NONMAGNETIC	SHEET 2 OF 2

APPROVED 8 MAY 1957 REVISED For changes see sheets 1 and 2