

MS16286A  
6 April 1997  
Superseding  
MS16286  
24 September 1957

MILITARY SPECIFICATION SHEET

NUT, HEXAGON, FINISHED, HEAVY, UNC-2B AND 8N-2B,  
HIGH TEMPERATURE - TO 1000°F

This specification is approved for use by all Departments  
and Agencies of the Department of Defense.

The requirements for acquiring the product described herein shall consist  
of this specification sheet and the issue of the following specification listed  
in that issue of the Department of Defense Index of Specifications and  
Standards (DoDISS) specified in the solicitation: MIL-S-1222.

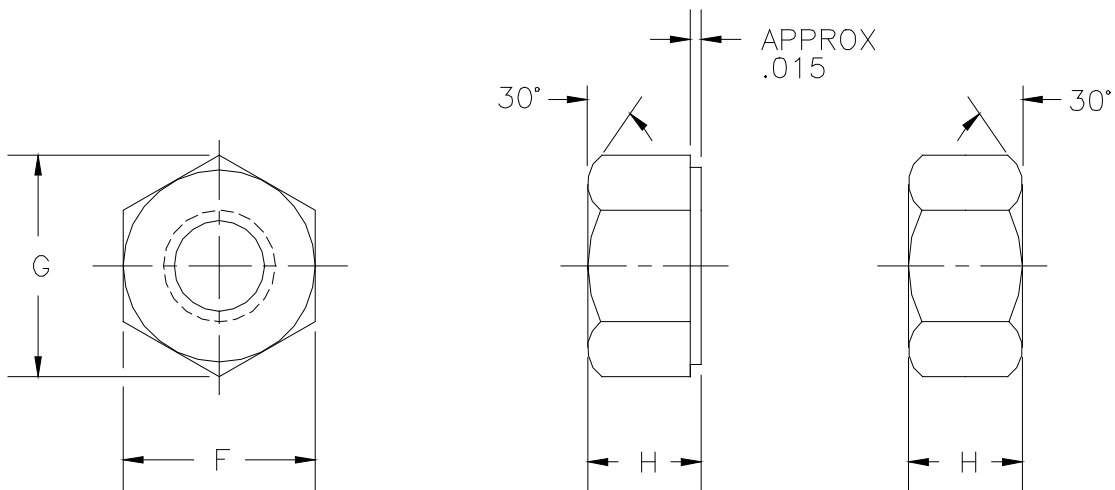

Ⓐ Entire document revised

Table I. Dash Numbers and Dimensions.

Dash Number	Size	Threads Per Inch	Width Across Flats F		Width Across Corners G		Thickness H	
			Max	Min	Max	Min	Max	Min
-1	.2500	20UNC-2B	.4375	.428	.505	.488	.226	.212
-2	.3125	18UNC-2B	.5000	.489	.577	.557	.273	.258
-3	.3750	16UNC-2B	.5625	.551	.650	.628	.337	.320
-4	.4375	14UNC-2B	.6875	.675	.794	.768	.385	.365
-5	.5000	13UNC-2B	.7500	.736	.866	.840	.448	.427
-6	.5625	12UNC-2B	.8750	.861	1.010	.982	.496	.473
-7	.6250	11UNC-2B	.9375	.922	1.083	1.051	.559	.535
-8	.7500	10UNC-2B	1.1250	1.088	1.299	1.240	.665	.617
-9	.8750	9UNC-2B	1.3125	1.269	1.516	1.447	.776	.724
-10	1.0000	8UNC-2B	1.5000	1.450	1.732	1.653	.887	.831
-11	1.1250	8UN-2B	1.6875	1.631	1.949	1.859	.999	.939
-12	1.2500	8UN-2B	1.8750	1.812	2.165	2.066	1.094	1.030
-13	1.3750	8UN-2B	2.0625	1.994	2.382	2.273	1.206	1.138
-14	1.5000	8UN-2B	2.2500	2.175	2.598	2.480	1.317	1.245
-15	1.7500	8UN-2B	2.6250	2.538	3.031	2.893	1.540	1.460
-16	2.0000	8UN-2B	3.0000	2.900	3.464	3.306	1.763	1.675
-17	2.2500	8UN-2B	3.3750	3.262	3.897	3.719	1.970	1.874
-18	2.5000	8UN-2B	3.7500	3.625	4.330	4.133	2.193	2.089
-19	2.7500	8UN-2B	4.1250	3.988	4.763	4.546	2.415	2.303
-20	3.0000	8UN-2B	4.5000	4.350	5.196	4.959	2.638	2.518

Requirements:

1. MATERIAL: Material shall be alloy steel, carbon-molybdenum, Grade 4 in accordance with MIL-S-1222, or alloy steel, chromium-molybdenum, Grade 7 in accordance with MIL-S-1222.
2. THREAD: The threads shall be in accordance with ASME B1.1. Thread acceptability shall be in accordance with ASME B1.3M, System 21.
3. Use: These nuts are for use in high temperature piping systems.
4. PART NUMBER: The MS part number consists of the MS number, plus the dash number from Table I.

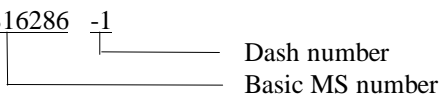
Example: MS16286 -1  

NOTES:

1. Dimension are in inches unless otherwise specified.
2. Interpret drawing in accordance with ASME Y14.5M.
3. In the event of a conflict between the text of this document and the references cited herein, the text of this document shall take precedence.
4. Unless otherwise specified, issues of referenced documents are those in effect at the time of solicitation.

Military Interests:

Custodians:

Army - AR

Navy - SH

Reviewer:

Army - ME, MI

Preparing activity:

DLA - IS

(Project 5310-2295)