

TABLE I

NOMINAL SIZE	(#0) .060	(#6) .138	(#8) .164	(#10) .190	(1/4) .250	(5/16) .3125							
THREADS PER INCH UNF-3A	60	40	35	32	20	24							
D BODY DIAMETER	MAX MIN	.0600 .0548	.1380 .1329	.1640 .1585	.1900 .1840	.2500 .2435	.3125 .3053						
A HEAD DIAMETER	MAX MIN	.096 .091	.226 .218	.270 .262	.3125 .303	.3750 .365	.4688 .457						
H HEAD HEIGHT	MAX MIN	.060 .057	.138 .134	.164 .159	.190 .185	.250 .244	.3125 .306						
S HEAD SIDE HGT	MIN	.054	.124	.148	.171	.225	.281						
J SOCKET WIDTH ACROSS FLATS	MAX MIN	.0510 .0500	.1111 .1094	.1424 .1406	.1587 .1562	.1900 .1875	.2330 .2300						
T KEY ENGAGEMENT	MIN	.023	.064	.077	.090	.120	.151						
G WALL THICKNESS	MIN	.020	.047	.058	.065	.095	.119						
K CHAMFER OR RADIUS	MAX	.003	.003	.005	.005	.006	.008						
R FILLET EXTENSION	MAX MIN	.007 .003	.010 .006	.012 .007	.014 .009	.014 .009	.017 .012						
TENSILE STRENGTH LBS - MIN		270	1,370	2,290	3,110	5,600	9,100						
L LENGTH	TOLERANCE	DASH NO.	DASH NO.	DASH NO.	DASH NO.	GRIP LENGTH MAX	BODY LENGTH MIN	DASH NO.	GRIP LENGTH MAX	BODY LENGTH MIN	DASH NO.	GRIP LENGTH MAX	BODY LENGTH MIN
.125	+.000 -.031	1											
.188		2											
.250		3	9										
.375		4	10	18	26		40				55		
.500		5	11	19	27		41						
.625	+.000 -.040		12	21	28						56		
.750			13	21	29		42				57		
.875					30		43				58		
1.000					31		44				59		
							45						
1.250	+.000 -.040				32	.175	.167	46			60		
1.500					33	.175	.167	47	.500	.250	61		
1.750					34	.875	.667	48	.500	.250	62	.625	.347
2.000					35	.875	.667	49	1.000	.750	63	.625	.347
2.250								50	1.000	.750	64	1.125	.847
2.500											65	1.125	.847

For notes see sheet 2.

(E) For changes see sheets 1, thru 3.

P.A. WC Drawn 99	TITLE (E) SCREW,CAP,SOCKET HEAD AND SCREW,CAP,SOCKET HEAD,SELF-LOCKING; ALLOY STEEL,CADMIUM PLATED,UNF-3A	MILITARY STANDARD MS16998
PROCUREMENT SPECIFICATION FF-S-86	SUPERSEDED BY: 3.1, 3.2; BOXES 4 and 4.2 MS33436, MS33438 and MS33460 in part	SHEET 1 OF 3

REVIEWED BY: AT, AY, BA, BB, BC, BD, BE, BF, BG, BH, BI, BJ, BK, BL, BM, BN, BO, BP, BQ, BR, BS, BT, BU, BV, BW, BX, BY, BZ, CA, CB, CC, CD, CE, CF, CG, CH, CI, CJ, CK, CL, CM, CN, CO, CP, CQ, CR, CS, CT, CU, CV, CW, CX, CY, CZ, DA, DB, DC, DD, DE, DF, DG, DH, DI, DJ, DK, DL, DM, DN, DO, DP, DQ, DR, DS, DT, DU, DV, DW, DX, DY, DZ, EA, EB, EC, ED, EE, EF, EG, EH, EI, EJ, EK, EL, EM, EN, EO, EP, EQ, ER, ES, ET, EU, EV, EW, EX, EY, EZ, FA, FB, FC, FD, FE, FF, FG, FH, FI, FJ, FK, FL, FM, FN, FO, FP, FQ, FR, FS, FT, FU, FV, FW, FX, FY, FZ, GA, GB, GC, GD, GE, GF, GG, GH, GI, GJ, GK, GL, GM, GN, GO, GP, GQ, GR, GS, GT, GU, GV, GW, GX, GY, GZ, HA, HB, HC, HD, HE, HF, HG, HH, HI, HJ, HK, HL, HM, HN, HO, HP, HQ, HR, HS, HT, HU, HV, HW, HX, HY, HZ, IA, IB, IC, ID, IE, IF, IG, IH, II, IJ, IK, IL, IM, IN, IO, IP, IQ, IR, IS, IT, IU, IV, IW, IX, IY, IZ, JA, JB, JC, JD, JE, JF, JG, JH, JI, JJ, JK, JL, JM, JN, JO, JP, JQ, JR, JS, JT, JU, JV, JW, JX, JY, JZ, KA, KB, KC, KD, KE, KF, KG, KH, KI, KJ, KK, KL, KM, KN, KO, KP, KQ, KR, KS, KT, KU, KV, KW, KX, KY, KZ, LA, LB, LC, LD, LE, LF, LG, LH, LI, LJ, LK, LL, LM, LN, LO, LP, LQ, LR, LS, LT, LU, LV, LW, LX, LY, LZ, MA, MB, MC, MD, ME, MF, MG, MH, MI, MJ, MK, ML, MM, MN, MO, MP, MQ, MR, MS, MT, MU, MV, MW, MX, MY, MZ, NA, NB, NC, ND, NE, NF, NG, NH, NI, NJ, NK, NL, NM, NN, NO, NP, NQ, NR, NS, NT, NU, NV, NW, NX, NY, NZ, OA, OB, OC, OD, OE, OF, OG, OH, OI, OJ, OK, OL, OM, ON, OO, OP, OQ, OR, OS, OT, OU, OV, OW, OX, OY, OZ, PA, PB, PC, PD, PE, PF, PG, PH, PI, PJ, PK, PL, PM, PN, PO, PP, PQ, PR, PS, PT, PU, PV, PW, PX, PY, PZ, QA, QB, QC, QD, QE, QF, QG, QH, QI, QJ, QK, QL, QM, QN, QO, QP, QQ, QR, QS, QT, QU, QV, QW, QX, QY, QZ, RA, RB, RC, RD, RE, RF, RG, RH, RI, RJ, RK, RL, RM, RN, RO, RP, RQ, RR, RS, RT, RU, RV, RW, RX, RY, RZ, SA, SB, SC, SD, SE, SF, SG, SH, SI, SJ, SK, SL, SM, SN, SO, SP, SQ, SR, SS, ST, SU, SV, SW, SX, SY, SZ, TA, TB, TC, TD, TE, TF, TG, TH, TI, TJ, TK, TL, TM, TN, TO, TP, TQ, TR, TS, TT, TU, TV, TW, TX, TY, TZ, UA, UB, UC, UD, UE, UF, UG, UH, UI, UJ, UK, UL, UM, UN, UO, UP, UQ, UR, US, UT, UY, UZ, VA, VB, VC, VD, VE, VF, VG, VH, VI, VJ, VK, VL, VM, VN, VO, VP, VQ, VR, VS, VT, VU, VV, VW, VX, VY, VZ, WA, WB, WC, WD, WE, WF, WG, WH, WI, WJ, WK, WL, WM, WN, WO, WP, WQ, WR, WS, WT, WU, WV, WW, WX, WY, WZ, XA, XB, XC, XD, XE, XF, XG, XH, XI, XJ, XK, XL, XM, XN, XO, XP, XQ, XR, XS, XT, XU, XV, XW, XX, XY, XZ, YA, YB, YC, YD, YE, YF, YG, YH, YI, YJ, YK, YL, YM, YN, YO, YP, YQ, YR, YS, YT, YU, YV, YW, YX, YY, YZ, ZA, ZB, ZC, ZD, ZE, ZF, ZG, ZH, ZI, ZJ, ZK, ZL, ZM, ZN, ZO, ZP, ZQ, ZR, ZS, ZT, ZU, ZV, ZW, ZX, ZY, ZZ

This military standard is approved for use by all Departments and Agencies of the Department of Defense. It is subject to change without notice and its use shall be restricted to that specified in this document, when applicable.

APPROVED 5 APR 1962 REVISED (A) 21 FEB 1963 (B) 15 JUL 1963 (C) 25 MAR 1965 (D) 22 OCT 1970 (E) 31 DEC 1976

TABLE I (Cont'd)

NOMINAL SIZE		(3/8)	(7/16)	(1/2)	(5/8)										
THREADS PER INCH UNF-3A		24	20	20	18										
D BODY DIAMETER	MAX	.3750	.4375	.5000	.6250										
	MIN	.3678	.4294	.4919	.6143										
A HEAD DIAMETER	MAX	.5625	.6562	.750	.9375										
	MIN	.550	.642	.735	.921										
H HEAD HEIGHT	MAX	.375	.4375	.500	.625										
	MIN	.368	.430	.492	.616										
S HEAD SIDE HGT	MIN	.337	.394	.450	.562										
J SOCKET WIDTH ACROSS FLATS	MAX	.3160	.3790	.3790	.5050										
	MIN	.3125	.3750	.3750	.5000										
T KEY ENGAGEMENT	MIN	.162	.213	.245	.307										
C WALL THICKNESS	MIN	.143	.166	.190	.236										
Z CHAMFER OR RADIUS	MAX	.008	.010	.010	.010										
R FILLET EXTENSION	MAX	.020	.023	.026	.032										
	MIN	.015	.018	.020	.024										
TENSILE STRENGTH 1*5 - MIN		11,800	18,700	25,200	40,400										
LENGTH	TOLERANCE		DASH NO.	GRIP LENGTH MAX	BODY LENGTH MIN	(E) DASH NO.	GRIP LENGTH MAX	BODY LENGTH MIN	DASH NO.	GRIP LENGTH MAX	BODY LENGTH MIN	DASH NO.	GRIP LENGTH MAX	BODY LENGTH MIN	
	SIZE	OVER													
.500			70			86									
.625			71												
.750	+0.000	+0.000	72							95			106		
.875	-0.011	-0.011	73												
1.000			74												
1.250			75			89			96			107			
1.500			76						97			108			
1.750	+0.000	+0.000	77	.500	.187			.625	.268	98			109		
2.000	-0.040	-0.060	78	.500	.187					99			110		
2.250			79	1.000	.687				100	.750	.365	111			
2.500			80	1.000	.687				101	.750	.365	112	.750	.295	
3.000			81	1.500	1.187				102	1.500	1.115	113	.750	.295	

NOTES:

- MATERIAL: Alloy steel in accordance with procurement specification.
- PROTECTIVE COATING: Cadmium plated in accordance with procurement specification.
- THREADS: The threads shall be in accordance with procurement specification.
- THREAD LENGTH: Screws above heavy line shall have complete (full form) threads extending within two threads of the head as measured with a thread ring gauge.
- DIMENSIONS: All dimensions are in inches unless otherwise specified.
- HEAD: The head may or may not be knurled, at the manufacturer's option. Type of knurling optional.
- SELF-LOCKING ELEMENT: (a) The self-locking element shall be a patch type or longitudinal strip in accordance with Mil-F-18240.
(b) For "I" and "T" dimensions, design and usage limitations, see MS15981.
(c) Maximum ring gage diameter that the locking region of screw must pass thru freely or with finger pressure shall be the nominal size plus 0.010.
- TENSILE STRENGTH: Based on 160,000 PSI minimum ultimate tensile strength. Load pounds are calculated by the stress area indicated in the Screw-Thread Standards for Federal Services, Handbook M28.
- PART NUMBER: The MS part number consists of the MS number, plus the dash number. For screws with the self-locking element add the letter "L" after the dash number.
Example: MS16998-1 Plain Screw
MS16998-1L Self-locking Screw
- Referenced documents shall be of the issue in effect on date of invitations for bid.
- For design feature purposes, this standard takes precedence over procurement documents referenced herein.

(E) NOW INACTIVE FOR NEW DESIGN AFTER 31 DECEMBER 1976.

This military standard is approved for use by all Departments and Agencies of the Department of Defense. Selection for all new engineering and design applications and for repetitive use shall be made from this document, when applicable.

APPROVED 5 APR 1962 REVISED (E) For changes see sheets 1 thru 1

P.A. MC	TITLE	MILITARY STANDARD
Other Com AS 99	(E) SCREW, CAP, SOCKET HEAD AND SCREW, CAP, SOCKET HEAD, SELF-LOCKING; ALLOY STEEL, CADMIUM PLATED, UNF-3A	MS16998
PROCUREMENT SPECIFICATION 77-5-86	SUPERSEDES: MS16998, J.1, J.2; MS16998 and 4.2 MS33456, MS33458 and MS33460 in part	SHEET 2 OF 5

REVISIONS: AF, AV, LA, LS, MI, MU, MSB, OS
USR: M, PA, W, YD

TABLE II
INTERCHANGEABILITY TABLE

The screws covered by dash numbers given in MS35456, MS35458 and MS35460 that are replaced by applicable dash numbers in this document are cancelled after 5 April 62. Use the dash numbers given in the preceding sheets. The cancelled screws cannot always replace the new screws and should be used until existing stocks are depleted. Use only the new screws for design and replacement. Replacement shall be in accordance with this table. Interchangeability information regarding part numbers on superseded drawings are also contained in this table.

PART NUMBERS		PART NUMBERS		PART NUMBERS	
CANCELLED	SUPERSEDING	CANCELLED	SUPERSEDING	CANCELLED	SUPERSEDING
MS35456 MS35458 MS35460	MS16998	MS35456 MS35458 MS35460	MS16998	MS35456 MS35458 MS35460	MS16998
Dash No.	Dash No.	Dash No.	Dash No.	Dash No.	Dash No.
1	9	22	42	53	61
2	10	23	43	62	93
3	11	24	44	63	96
4	12	25	45	64	97
5	13	26	46	65	98
6	18	27	47	66	99
7	19	28	48	67	100
8	21	29	49	68	101
10	26	30	50	69	102
11	27	42	70		
12	28	43	71		
13	29	44	72		
14	30	45	73		
15	31	46	74		
16	32	47	75		
17	33	48	76		
18	34	49	77		
19	35	50	78		
20	40	51	79		
21	41	52	80		

Screws covered by the following part numbers are inactive for Design and Engineering. They shall be used for maintenance of existing equipment to replace the 5/16, 7/16 and 5/8 inch size screws used in counterbored holes or other close applications.

PART NO.	PART NO.	PART NO.	PART NO.	PART NO.	PART NO.
INACTIVE	INACTIVE	INACTIVE	INACTIVE	INACTIVE	INACTIVE
MS35456 MS35458 MS35460	MS35456 MS35458 MS35460	MS35456 MS35458 MS35460	MS35456 MS35458 MS35460	MS35456 MS35458 MS35460	MS35456 MS35458 MS35460
Dash No.	Dash No.	Dash No.	Dash No.	Dash No.	Dash No.
31	35	38	55	71	73
32	36	40	56	72	76
33	37	41	58	73	77
34	38	54	70	74	

P.A. VC Other Cont AS 99	TITLE ⑤ SCREW, CAP, SOCKET HEAD AND SCREW, CAP, SOCKET HEAD, SELF-LOCKING; ALLOY STEEL, CADMIUM PLATED, UNF-3A	MILITARY STANDARD MS16998
PROUREMENT SPECIFICATION FY-5-86	SUPERSEDES (CIVIL) 3.3, 3.2, 3.1; BCX14 and 4.2 MS35456, MS35458 and MS35460 in part	SHEET 3 OF 3

This military standard is approved for use by all Departments and Agencies of the Department of Defense. Selection for all new engineering and design applications and for repetitive use shall be made from this document, when applicable.

APPROVED 5 APR 1962 REVISED 6 For changes see sheets 1 thru 5

P&H REF CLASS
5305

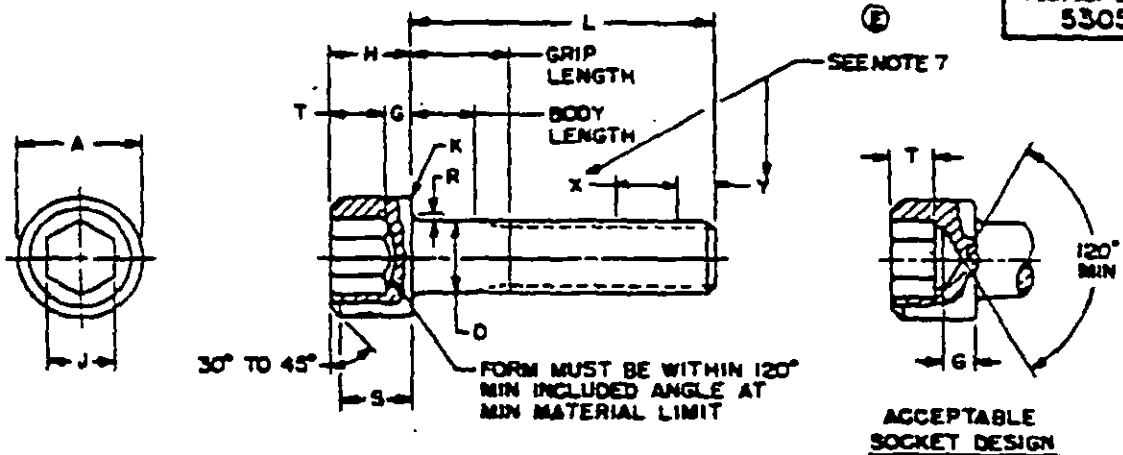

TABLE III
METRIC TRANSLATION OF TABLE I

NOMINAL SIZE mm	1.524	3.305	4.166	4.826	6.350	7.938				
THREADS PER 25.4 mm UNF-3A	60	40	36	32	28	24				
D BODY DIAMETER MAX MIN	1.524 1.443	3.305 3.376	4.166 4.028	4.826 4.674	6.350 6.185	7.938 7.735				
A HEAD DIAMETER MAX MIN	2.438 2.311	5.740 5.537	6.858 6.655	7.938 7.694	9.550 9.271	11.908 11.608				
H HEAD HEIGHT MAX MIN	1.524 1.448	3.305 3.404	4.166 4.039	4.826 4.699	6.350 6.198	7.938 7.772				
S HEAD SIDE HGT MIN	1.372	3.150	1.739	4.343	5.715	7.137				
J SOCKET WIDTH MAX ACROSS FLATS MIN	1.295 1.270	3.822 3.779	3.622 3.571	4.031 3.967	4.826 4.762	6.426 6.350				
T KEY ENGAGEMENT MIN	.635	1.626	1.936	2.284	3.049	3.835				
C WALL THICKNESS MIN	.508	1.184	1.422	1.651	2.413	3.023				
K CHAMFER OR RADIUS MAX	.076	.127	.127	.127	.203	.203				
R FILLET EXTENSION MAX MIN	.178 .076	.254 .152	.305 .178	.356 .229	.354 .229	.432 .305				
TENSILE STRENGTH MIN - MIN	1.215	7.065	10.305	13.995	25.360	40.950				
L LENGTH TOLERANCE DASH NO.										
3.175 4.775 6.350 9.525 12.700	+.000 -.787	1 2 3 4 5	9 10 11	18 19 26	26 27	40 41	55			
15.875 19.050 22.225 25.400			12 13	21 28	29 30 31	42 43 44 45	56 57 58 59			
31.750 38.100 44.450 50.800		+.000 -1.016			32 33 34 35	9.525 9.525 22.225 22.225	4.242 4.242 16.943 16.943	60 61 62 63	15.875 15.875	8.814 8.814
57.150 63.500					36 37	22.225 22.225	16.943 16.943	64 65	28.375 28.375	21.514 21.514
						38 39	12.700 12.700	6.350 6.350	66 67	
					40 41	25.400 25.400	19.050 19.050	68 69		

NOTE: All dimensions are in millimeters (mm) unless otherwise specified and are based on an approximate conversion factor of 25.4mm equal one inch.

This military standard is approved for use by all Departments and Agencies of the Department of Defense. Deviations for all new engineering and design applications and for repetitive use shall be made from this document, when applicable.

APPROVED 5 APR 1982 REVISED (E) For changes see sheets 1 thru 5

P.A. VC Qty 45 99	TITLE (E) SCREW, CAP, SOCKET HEAD AND SCREW, CAP, SOCKET HEAD, SELF-LOCKING; ALLOY STEEL, CADMIUM PLATED, UNF-3A	MILITARY STANDARD MS16998
PROPOSING ORGANIZATION FF-5-86	REFERENCES: BCS13, 3.1, 3.2; BCS14 and 4.2 MS15456, MS15458 and MS15460 in part.	SHEET 4 OF 5

TABLE III (Cont'd)
METRIC TRANSLATION OF TABLE I

NOMINAL SIZE mm	9.525	11.112	12.700	15.875										
THREADS per 25.4mm UNF-3A	24	20	20	18										
D BODY DIAMETER MAX	9.525	11.112	12.700	15.875										
MIN	9.342	10.907	12.494	15.634										
A HEAD DIAMETER MAX	14.288	16.667	19.050	23.812										
MIN	13.970	16.307	18.669	23.393										
H HEAD HEIGHT MAX	9.525	11.112	12.700	15.875										
MIN	9.347	10.922	12.497	15.646										
S HEAD SIDE HGT MIN	8.560	10.000	11.430	14.275										
J SOCKET WIDTH MAX	8.026	9.627	9.627	12.827										
ACROSS FLATS MIN	7.938	9.523	9.523	12.700										
T KEY ENGAGEMENT MIN	4.623	5.410	6.223	7.798										
G WALL THICKNESS MIN	3.632	4.216	4.826	6.045										
K CRANFER OR RADIUS MAX	.203	.254	.254	.254										
R FILLET EXTENSION MAX	.508	.584	.660	.813										
MIN	.381	.457	.508	.610										
Q TENSILE STRENGTH LN - MIN (E)	62.100	84.150	113.400	181.800										
L LENGTH	TOLERANCE		DASH NO.	GRIP LENGTH MAX	BODY LENGTH MIN	DASH NO.	GRIP LENGTH MAX	BODY LENGTH MIN	DASH NO.	GRIP LENGTH MAX	BODY LENGTH MIN	DASH NO.	GRIP LENGTH MAX	BODY LENGTH MIN
	SIZE	OVER												
	9.525	9.525												
12.700			70											
15.875			71											
19.050	+.000	+.000	72											
22.225	-.787	-.787	73											
25.400			74						93				106	
31.750			75						96				107	
38.100			76						97				108	
44.450	+.000	+.000	77	12.700	4.750				98				109	
50.800	-1.016	-1.524	78	12.700	4.750	89	15.875	6.807	99				110	
57.150			79	25.400	17.450				100	19.050	9.271		111	
63.500			80	25.400	17.450				101	19.050	9.271		112	19.050
69.850			81	38.100	30.150				102	38.100	28.321		113	19.050
														7.493
														7.493

NOTE: All dimensions are in millimeters (mm), unless otherwise specified and are based on an approximate conversion factor of 25.4mm equal one inch.

(E) ** INACTIVE FOR NEW DESIGN AFTER 31 DECEMBER 1976.

U. S. GOVERNMENT PRINTING OFFICE: 1977-703-020/1079

P.A. 01	TITLE	MILITARY STANDARD
Other Code AS 99	(E) SCREW, CAP, SOCKET HEAD AND SCREW, CAP, SOCKET HEAD, SELF-LOCKING: ALLOY STEEL, CADMIUM PLATED, UNF-3A	MS 16998
PROCUREMENT SPECIFICATION FF-S-86	SUPERSEDES BCW1, 3.1, 3.2; BCW14 and 4.2 MS33456, MS33458 and MS33460 in part.	SHEET 5 OF 5

REVISED: AT, AL, CA, CA, IS, MI, NI, NSA, OS
USA: NE, PA, W, YD

This military standard is approved for use by all Departments and Agencies of the Department of Defense. Selection for all new engineering and design applications and for repetitive use shall be made from this document, when applicable.

APPROVED 5 APR 1982 REVISED (E) For changes see sheets 1 thru 5