

FED. SUP CLASS
6210

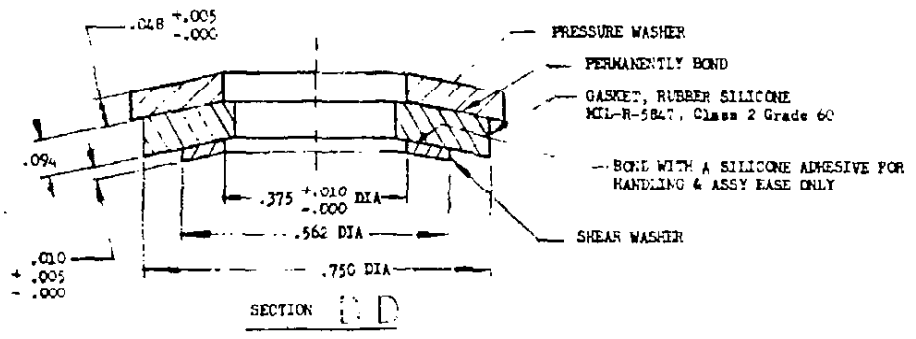
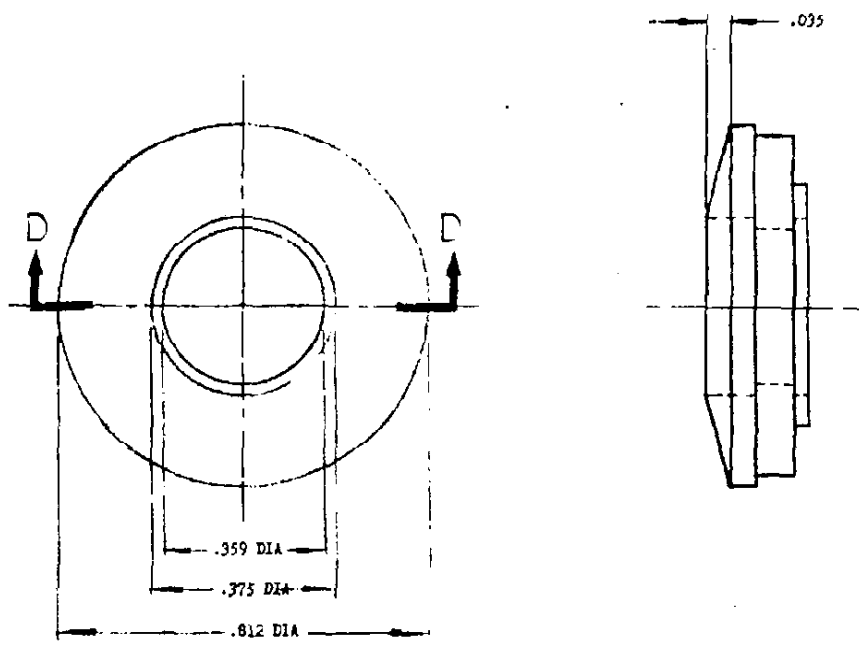

1. MATERIAL: WASHER, ALLOY STEEL, FEDERAL STANDARD NO. 68, STEEL, RUST (CORROSION) 4130. GASKET, HEAT-RESISTANT SILICONE RUBBER, CLASS II, GRADE 60, MIL-R-5847.
2. WASHERS SHALL BE FREE FROM ALL HANGING BURRS AND SLIVERS WHICH BECOME DISLOOGED UNDER USAGE.
3. DIMENSIONS IN INCHES. UNLESS OTHERWISE SPECIFIED, TOLERANCES: DECIMALS ±.015.

FOR DESIGN FEATURE PURPOSES, THIS STANDARD TAKES PRECEDENCE OVER PROCUREMENT DOCUMENTS REFERENCED HEREIN.
 REFERENCED DOCUMENTS SHALL BE OF THE ISSUE IN EFFECT ON DATE OF INVITATIONS FOR BID.

Review activities:
 This military standard is approved by the Department of the Air Force and the Naval Air Systems Command and is mandatory for use by these activities. All other military activities are required to employ this standard where applicable.

APPROVED 11 Sept 68 REVISED

P.A. Navy - AS Other Comd USAF - 11	TITLE SEAL, COVER BOLT, COMPRESSION TYPE	MILITARY STANDARD	
		MS21205(ASG)	
PROCUREMENT SPECIFICATION MIL-R-8925	SUPERSEDES:	SHEET 1 OF 1	