

REQUIREMENTS FOR ACQUIRING THE PRODUCT(S) DESCRIBED HEREIN SHALL CONSIST OF THIS SPECIFICATION SHEET AND THE ISSUE OF THE FOLLOWING SPECIFICATION LISTED IN THAT ISSUE OF THE DDSSB SPECIFIED IN THE SOLICITATION:

THIS SPECIFICATION IS APPROVED FOR USE BY ALL DEPARTMENTS AND AGENCIES OF THE DEPARTMENT OF DEFENSE.

FORM APPROVED
OMB NO. 0704-0188

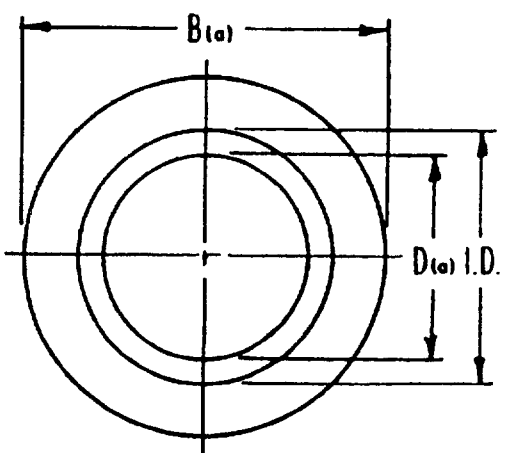

COUNTERSUNK WASHER
(FOR USE UNDER BOLT HEAD)

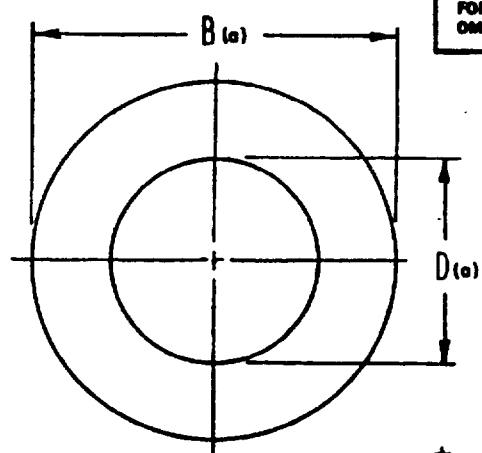

PLAIN WASHER
(FOR USE UNDER NUT)

| NOMINAL SIZE | DASH NUMBER | | B(a) | | D(a) | | I.D. | | V | | FLATNESS MAX | APPROX WEIGHT LB/100 |
|--------------|-------------|-------|-------|-------|-------|-------|-------|-------|------|------|--------------|----------------------|
| | CSK. | PLAIN | MAX | MIN | MAX | MIN | MAX | MIN | MAX | MIN | | |
| #10 | C3 | 3 | .372 | .362 | .195 | .191 | .290 | .280 | .069 | .057 | .007 | .13 |
| 1/4 | C4 | 4 | .470 | .460 | .255 | .251 | .350 | .340 | | | | .21 |
| 5/16 | C5 | 5 | .573 | .563 | .318 | .314 | .412 | .402 | .31 | | | |
| 3/8 | C6 | 6 | .679 | .669 | .380 | .376 | .507 | .497 | .43 | | | |
| 7/16 | C7 | 7 | .783 | .773 | .443 | .439 | .569 | .559 | .57 | | | |
| 1/2 | C8 | 8 | .898 | .888 | .505 | .501 | .632 | .622 | .085 | .071 | .75 | |
| 9/16 | C9 | 9 | 1.009 | .999 | .568 | .564 | .694 | .684 | | | .95 | |
| 5/8 | C10 | 10 | 1.125 | 1.115 | .631 | .627 | .788 | .778 | .10 | | 1.18 | |
| 3/4 | C12 | 12 | 1.350 | 1.340 | .756 | .752 | .913 | .903 | | | 1.71 | |
| 7/8 | C14 | 14 | 1.572 | 1.562 | .881 | .877 | 1.038 | 1.028 | | | 2.32 | |
| 1 | C16 | 16 | 1.798 | 1.788 | 1.006 | 1.002 | 1.163 | 1.153 | .119 | .099 | 3.04 | |
| 1 1/8 | C18 | 18 | 2.188 | 2.178 | 1.131 | 1.127 | 1.288 | 1.278 | | | 4.81 | |
| 1 1/4 | C20 | 20 | 2.260 | 2.250 | 1.256 | 1.252 | 1.445 | 1.435 | | | 4.84 | |
| 1 3/8 | C22 | 22 | 2.490 | 2.480 | 1.381 | 1.377 | 1.570 | 1.560 | .015 | | 5.89 | |
| 1 1/2 | C24 | 24 | 2.723 | 2.713 | 1.506 | 1.502 | 1.695 | 1.685 | | | 7.06 | |

(a) MINIMUM BEARING AREA BASE ON A BEARING STRESS OF 90 KSI AT THE ULTIMATE TENSILE VALUE OF A 220 KSI BOLT; OR THE FLANGE DIAMETER OF MS21084 NUTS WHICHEVER IS GREATER.

MATERIAL: ALLOY STEEL, MIL-S-6758, MIL-S-18729.

HARDNESS: ROCKWELL C 38-45

SURFACE TEXTURE: 125 MICROINCHES IN ACCORDANCE WITH ANSI B46.1.

PLATING: CADMIUM PLATE, QQ-P-416, TYPE II, CLASS 2.

PARALLELISM: WASHER FACES SHALL BE PARALLEL WITHIN .002 INCHES.

WASHER SHALL BE FREE FROM ALL HANGING BURRS AND SLIVERS WHICH MIGHT BECOME DISLODGED UNDER USAGE.

DIMENSIONS IN INCHES.

DESIGN AND USAGE INFORMATION: THESE WASHERS ARE PRIMARILY FOR USE WITH MS21133 & MS21084 NUTS AND MS21134 AND MS21297 BOLTS.

EXAMPLE OF PART NUMBER: MS21206-3 WASHER, PLAIN, FOR NO. 10 SIZE, 220 KSI BOLT.
MS21206-C3 WASHER, COUNTERSUNK, FOR NO. 10 SIZE, 220 KSI BOLT.

FOR DESIGN FEATURE PURPOSES, THIS STANDARD TAKES PRECEDENCE OVER PROCUREMENT DOCUMENTS REFERENCED HEREIN. REFERENCED DOCUMENTS SHALL BE OF THE ISSUE IN EFFECT ON DATE OF INVITATIONS FOR BID.

(A) DENOTES CHANGE

| | | | |
|--------------------------------------------------------------------------------------------------------------------------------------------------------------------|------------------------------------------------------------------------------------------------------------------------------------------------------|----------------------------------------------|--------------------|
| PREPARING ACTIVITY: NAVY - AS CUSTODIANS: ARMY - AY NAVY - AIR FORCE - 99 DLA - REVIEW: AIR FORCE -82 USER: PROJECT NUMBER: 5310-1785 | MILITARY SPECIFICATION SHEET TITLE WASHER, COUNTERSUNK AND PLAIN, FOR USE WITH BOLTS AND NUTS UP TO AND INCLUDING 220 KSI Ftu | SPECIFICATION SHEET NUMBER MS21206 | 30 AUG 91 REV A |
| | | SUPERSEDING MS21206 | 28 JAN 72 |
| DISTRIBUTION STATEMENT A. APPROVED FOR PUBLIC RELEASE; DISTRIBUTION IS UNLIMITED. | | AMSC - M/A | FSC 6310 |

Ⓐ INACTIVE FOR NEW DESIGN AFTER 30 SEP 92,
USE MS21299 IN NEW DESIGN.

Ⓐ INTERCHANGEABILITY RELATIONSHIP: MS21299 ITEMS CAN UNIVERSALLY REPLACE
THE INACTIVE MS21206 ITEMS IDENTIFIED BY THE SAME DASH NUMBERS: BUT THE
INACTIVE MS21206 ITEMS CANNOT ALWAYS REPLACE THE SUPERSEDING MS21299 ITEMS.

| | | |
|----------------------------------------------------------------------------------------------------------------------------------------------------------------|--------------------------------------------------------------------------------------------------------------------------------------------------|----------------------------------------------------------------------------------------------------------------------------------|
| PREPARING ACTIVITY: NAVY - AS CUSTOMIANS: ARMY - AY NAVY - AIR FORCE - 99 DLA - REVIEW: AIR FORCE -82 USER: PROJECT NUMBER: 5310-1785 | MILITARY SPECIFICATION SHEET TITLE WASHER, COUNTERSUNK AND PLAIN, FOR USE WITH BOLTS AND NUTS UP TO AND INCLUDING 220 KSI Ftu | SPECIFICATION SHEET NUMBER 30 AUG 91 MS21206 REV A SUPERSEDING MS21206 28 JAN72 AMSC - N/A FBC 5310 |
| DISTRIBUTION STATEMENT A. APPROVED FOR PUBLIC RELEASE; DISTRIBUTION IS UNLIMITED. | | PAGE 2 OF 2 |