

FED. SUP CLASS  
5310

USER SYMBOLS:

REVIEWER SYMBOLS:

NAVY - AS  
USAF - 11  
ARMY - AV  
DLA - ER

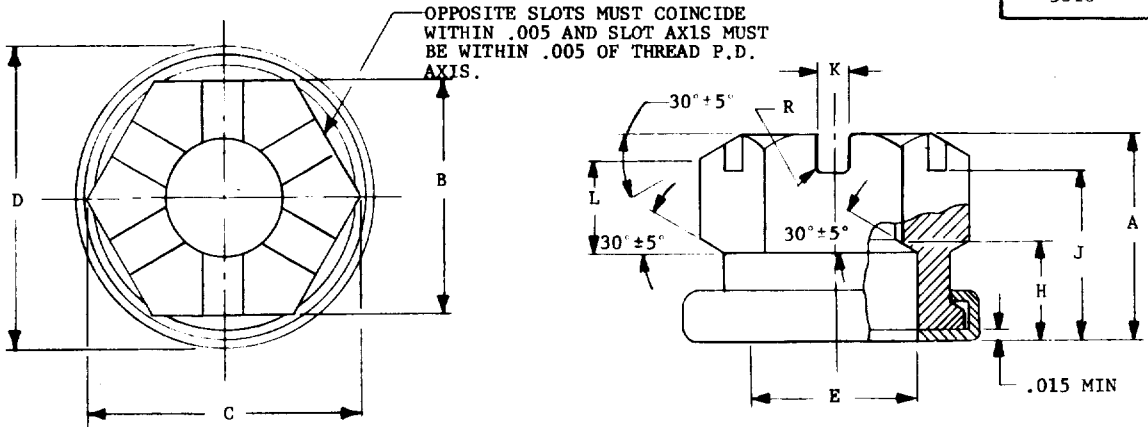

"Review/user" information is current as of the date of this document.  
 For future coordination of changes to this document, draft circulation  
 should be based on the information in the current DDISS."

This military standard is approved for use by all Departments  
 & Agencies of the Department of Defense. Selection for all new  
 engineering and design applications and for repetitive use shall  
 be made from this document.

SIZE DASH NO. △	(a) THREADS PER MIL-S-8879	A		B		C		D		E		H	
		MAX	MIN	MAX	MIN	MIN	MAX	MIN	(b)		(c)		
									MAX	MIN	MAX	MIN	
-3	.1900-32UNJF-3B	.390	.370	.376	.367	.413	.490	.460	.240	.230	.161	.141	
-4	.2500-28UNJF-3B	.425	.405	.439	.430	.488	.560	.530	.309	.299	.192	.172	
-5	.3125-24UNJF-3B	.466	.436	.502	.492	.557	.640	.610	.395	.385	.223	.203	
-6	.3750-24UNJF-3B	.502	.482	.564	.553	.628	.710	.680	.460	.450	.238	.218	
-7	.4375-20UNJF-3B	.550	.530	.627	.616	.698	.785	.755	.529	.519	.269	.249	
-8	.5000-20UNJF-3B	.596	.576	.752	.741	.840	.925	.895	.614	.604	.301	.281	
-9	.5625-18UNJF-3B	.710	.690	.877	.865	.988	1.080	1.050	.686	.676	.332	.312	
-10	.6250-18UNJF-3B	.822	.792	1.002	.990	1.121	1.224	1.194	.770	.760	.407	.387	
-12	.7500-16UNJF-3B	.951	.911	1.064	1.052	1.191	1.283	1.253	.915	.905	.450	.430	
-14	.8750-14UNJF-3B	1.058	1.018	1.252	1.239	1.403	1.495	1.465	1.065	1.055	.495	.475	
-16	1.0000-12UNJF-3B	1.202	1.162	1.440	1.427	1.615	1.707	1.677	1.215	1.205	.544	.524	

SIZE DASH NO.	J		K		L	R	AXIAL STRENGTH LBS.	WEIGHT LBS/100
	MAX	MIN	MAX	MIN	MIN	MAX		
-3	.279	.259	.108	.078	.110	.035	1,105	1.04
-4	.316	.296			2,040		1.40	
-5	.347	.327			3,250		1.72	
-6	.378	.358	.155	.125	.140	.053	5,050	2.13
-7	.409	.389			.130		6,800	2.50
-8	.472	.452			.150		9,250	4.40
-9	.550	.530	.187	.157	.165	.062	11,800	7.40
-10	.633	.613			.170		15,050	7.90
-12	.765	.745			.220		22,000	8.60
-14	.871	.851	.288	30,000	16.70			
-16	.984	.964	.333	40,350	19.80			

FOR DESIGN FEATURE PURPOSES THIS STANDARD TAKES PRECEDENCE OVER PROCUREMENT DOCUMENTS REFERENCED HEREIN.

REFERENCED DOCUMENTS SHALL BE OF THE ISSUE IN EFFECT ON DATE OF INVITATIONS FOR BID.

(A) ENTIRE STANDARD REVISED & REDRAWN, (B) DENOTES CHANGES

P.A. NAVY - AS Other Cust USAF - 11 ARMY - AV	INTER- NATIONAL INTEREST **	TITLE NUT, CASTELLATED, HEXAGON, COUNTERBORED ASSEMBLED WASHER, 450°F (FOR SELF-RETAINING BOLTS)	MILITARY STANDARD <b>MS21244</b>
PROCUREMENT SPECIFICATION FF-N-836	SUPERSEDES	SHEET 1 OF 2	

APPROVED 12 JAN 68 REVISED A 7 DEC 73 B 28 AUG 1981

USER SYMBOLS:

REVIEWER SYMBOLS:

NAVY - AS  
USAF - 11  
ARMY - ER  
DLA - IS

"Review/user information is current as of the date of this document. For future coordination of changes to this document, draft circulation should be based on the information in the current DODISS."

This military standard is approved for use by all Departments & Agencies of the Department of Defense. Selection for all new engineering and design applications and for repetitive use shall be made from this document.

- (a) NUTS WILL ASSEMBLE ON EITHER MIL-S-7742 OR MIL-S-8879 THREADED BOLTS.
- (b) CONCENTRICITY: "E" TO BE CONCENTRIC TO P.D. OF THREAD WITHIN .005 TIR.
- (c) WASHER I.D. MAY BE .005 LESS THAN "E" MIN.

NOTES:

1. MATERIAL: a. BODY: STEEL (SEE PROCUREMENT SPECIFICATION.) ; CRES (A286) LUBRICATED  
b. WASHER: CRES 302 OR 321
2. PROTECTIVE TREATMENT: a. STEEL, CADMIUM PLATING IN ACCORDANCE WITH QQ-P-416, TYPE II, CLASS 2. PARTS WITH CLASS 3 PLATING MAY BE FURNISHED FROM SUPPLIERS STOCK UNTIL JUNE 1974.  
b. CRES-PASSIVATE IN ACCORDANCE WITH QQ-P-35.
3. THREADED ELEMENT SHALL ROTATE FREELY IN AND AGAINST THE WASHER.
4. SURFACE TEXTURE IN ACCORDANCE WITH ANSI-B-46.1 SHALL NOT EXCEED 125 MICRO INCHES.
5. BREAK ALL SHARP EDGES AND REMOVE BURRS AND SLIVERS.
6. DIMENSIONS IN INCHES. UNLESS OTHERWISE SPECIFIED, TOLERANCE: DECIMALS ± .010
7. DESIGN INFORMATION: THESE NUTS ARE FOR USE WITH SELF-RETAINING BOLTS AND MAY BE USED AT TEMPERATURES 450°F AND BELOW. FOR DESIGN USAGE LIMITATIONS SEE MS33602. NUTS ARE TO BE INSTALLED IN ACCORDANCE WITH MS33540.
8. EXAMPLE OF PART NUMBER: MS21244-4 = .2500-28 STEEL CADMIUM PLATED.  
MS21244-10C = .6250-18 CRES, PASSIVATED. LUBRICATED
- △ 9. ADD "C" AFTER DASH NUMBER TO INDICATE CRES
10. MAGNETIC PERMEABILITY OF CRES NUTS SHALL BE LESS THAN 2.0(AIR=1.0) FOR A FIELD STRENGTH H = 200 OERSTEDS USING A MAGNETIC PERMEABILITY INDICATOR IN ACCORDANCE WITH MIL-I-17214 OR EQUIVALENT.

\* CERTAIN PROVISIONS FOR ACROSS FLAT DIMENSIONS OF THIS STANDARD ARE THE SUBJECT OF INTERNATIONAL STANDARDIZATION AGREEMENT (ABC AIR STD 17/2). WHEN REVISION, OR CANCELLATION OF THIS STANDARD IS PROPOSED WHICH WILL AFFECT OR VIOLATE THE INTERNATIONAL AGREEMENT CONCERNED, THE PREPARING ACTIVITY WILL TAKE APPROPRIATE RECONCILIATION ACTION THROUGH INTERNATIONAL STANDARDIZATION CHANNELS, INCLUDING DEPARTMENTAL STANDARDIZATION OFFICES, IF REQUIRED.

APPROVED 12 JAN 68 REVISED B FOR CHANGES SEE SHEET 1

P.A. NAVY - AS Other Cust USAF-11 ARMY-AV	INTER- NATIONAL INTEREST *	TITLE	MILITARY STANDARD
		NUT, CASTELLATED, HEXAGON, COUNTERBORED ASSEMBLED WASHER, 450 F (FOR SELF-RETAINING BOLTS)	MS21244
PROCUREMENT SPECIFICATION FF-N-836	SUPERSEDES:	SHEET 2 OF 2	