

MS21283 AND MANUFACTURER'S IDENTIFICATION
.047 MIN. HIGH CHARACTERS RAISED OR
DEPRESSED .010 MAX.

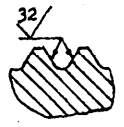
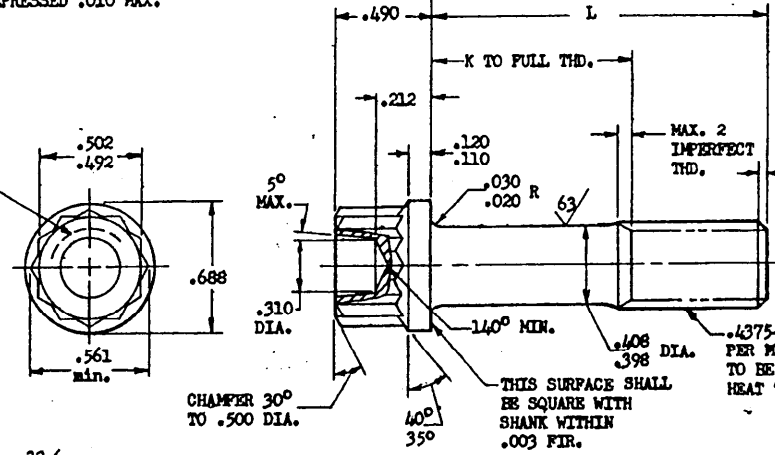

SECTION THRU THREAD PROFILE

PART NO.	L	K +.000 -.060	APPROX. WEIGHT LB/100	PART NO.	L	K +.000 -.060	APPROX. WEIGHT LB/100	PART NO.	L	K +.000 -.060	APPROX. WEIGHT LB/100
				MS21283-24	2.125	1.000	10.38	MS21283-45	4.750	3.625	20.12
				MS21283-25	2.250	1.125	10.85	MS21283-46	4.875	3.750	20.59
				MS21283-26	2.375	1.250	11.32	MS21283-47	5.000	3.875	21.05
MS21283-06	.812	(a)	5.51	MS21283-27	2.500	1.375	11.79	MS21283-48	5.125	4.000	21.51
MS21283-07	.875	(a)	5.74	MS21283-28	2.625	1.500	12.26	MS21283-49	5.250	4.125	21.97
MS21283-08	.938	(a)	5.97	MS21283-29	2.750	1.625	12.72	MS21283-50	5.375	4.250	22.33
MS21283-09	1.000	(a)	6.20	MS21283-30	2.875	1.750	13.19	MS21283-51	5.500	4.375	22.80
MS21283-10	1.062	(a)	6.43	MS21283-31	3.000	1.875	13.66	MS21283-52	5.625	4.500	23.27
MS21283-11	1.125	(a)	6.67	MS21283-32	3.125	2.000	14.12	MS21283-53	5.750	4.625	23.74
MS21283-12	1.188	(a)	6.90	MS21283-33	3.250	2.125	14.59	MS21283-54	5.875	4.750	24.21
MS21283-13	1.250	.125	7.13	MS21283-34	3.375	2.250	15.06	MS21283-55	6.000	4.875	24.67
MS21283-14	1.312	.188	7.36	MS21283-35	3.500	2.375	15.52				
MS21283-15	1.375	.250	7.59	MS21283-36	3.625	2.500	15.99				
MS21283-16	1.438	.312	7.82	MS21283-37	3.750	2.625	16.45				
MS21283-17	1.500	.375	8.05	MS21283-38	3.875	2.750	16.92				
MS21283-18	1.562	.438	8.27	MS21283-39	4.000	2.875	17.39				
MS21283-19	1.625	.500	8.50	MS21283-40	4.125	3.000	17.85				
MS21283-20	1.688	.562	8.73	MS21283-41	4.250	3.125	18.31				
MS21283-21	1.750	.625	8.96	MS21283-42	4.375	3.250	18.75				
MS21283-22	1.875	.750	9.43	MS21283-43	4.500	3.375	19.31				
MS21283-23	2.000	.875	9.90	MS21283-44	4.625	3.500	19.66				

(a) THREAD TO HEAD. MAXIMUM TWO IMPERFECT THREADS. EXCEPT INCOMPLETE THREADS NOT TO ENTER FILLET RADIUS.

- NOTE: (1) SHANK SHALL BE STRAIGHT WITHIN .0025 FIR. PER INCH OF BOLT LENGTH.
 (2) THE CONCENTRICITY OF THREAD PD IN RELATION TO THE SHANK SHALL BE WITHIN .006 FIR.
 (3) THE CONCENTRICITY OF THE SHANK IN RELATION TO THE WASHER FACE DIAMETER AND DOUBLE HEXAGON O.D. SHALL BE WITHIN .019 FIR.

MATERIAL: CORROSION AND HEAT RESISTANT STEEL AMS 5735
 MANUFACTURING SPECIFICATION: AMS 7478 EXCEPT HEADS TO BE FORMED BY HOT OR COLD UPSETTING
 PART SUBJECT TO FLUORESCENT PENETRANT INSPECTION PER AMS 2645
 SURFACE ROUGHNESS: MIL-STD-10 UNLESS OTHERWISE SPECIFIED, SURFACES TO BE 125 MICROINCHES
 BREAK SHARP EDGES .003-.015 UNLESS OTHERWISE SPECIFIED.
 DIMENSIONS IN INCHES. UNLESS OTHERWISE SPECIFIED; TOLERANCES; LINEAR DIMENSIONS ±.010, ANGULAR DIMENSIONS ±5°.
 DO NOT USE UNASSIGNED PART NUMBERS.

This standard was approved by the Bureau (Department of the Navy) and the Department of the USAF and is mandatory for use by that activity. All other military activities are required to employ this standard where suitable.

P.A. Navy - Wep	TITLE	MILITARY STANDARD
Other Cust Air Force - ASD	BOLT, MACHINE - STEEL, DOUBLE HEXAGON, EXTENDED WASHER, .4375-20 (MIL-S-8879 THREAD)	MS21283 (ASG)
PROCUREMENT SPECIFICATION	SUPERSEDES:	SHEET 1 OF 1
NONE		

APPROVED 1 MAY 61 REVISED (A) 23 OCT 61 (B) 17 SEP 63