

MS21288 AND MANUFACTURER'S IDENTIFICATION
.047 MIN. HIGH CHARACTERS RAISED OR
DEPRESSED .010 MIN.

.047 DIA. 4 HOLES
EQUALLY SPACED AS
SHOWN CSK 90° TO
.060 DIA.

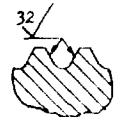
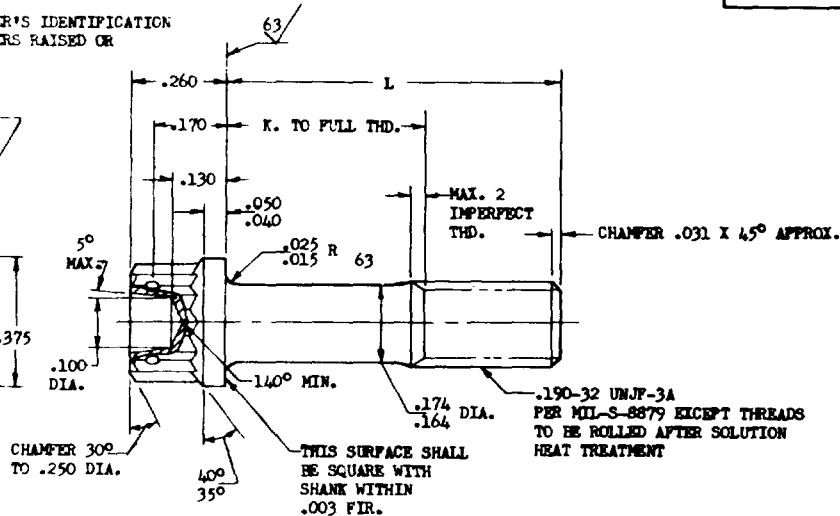
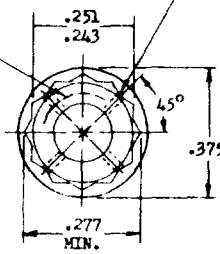

SECTION THRU THREAD PROFILE

PART NO.	L	K +.000 -.060	APPROX. WEIGHT LB/100	PART NO.	L	K +.000 -.060	APPROX. WEIGHT LB/100
MS21288-03	.312	(a)	.87				
MS21288-04	.375	(a)	.91				
MS21288-05	.438	(a)	.95				
MS21288-06	.500	(a)	.99	MS21288-23	1.562	.938	1.67
MS21288-07	.562	(a)	1.03	MS21288-24	1.625	1.000	1.71
MS21288-08	.625	(a)	1.07	MS21288-25	1.688	1.062	1.75
MS21288-09	.688	(a)	1.11	MS21288-26	1.750	1.125	1.79
MS21288-10	.750	.125	1.15	MS21288-27	1.875	1.250	1.87
MS21288-11	.812	.188	1.19	MS21288-28	2.000	1.375	1.95
MS21288-12	.875	.250	1.23	MS21288-29	2.125	1.500	2.03
MS21288-13	.938	.312	1.27	MS21288-30	2.250	1.625	2.11
MS21288-14	1.000	.375	1.31	MS21288-31	2.375	1.750	2.19
MS21288-15	1.062	.437	1.35	MS21288-32	2.500	1.875	2.27
MS21288-16	1.125	.500	1.39	MS21288-33	2.625	2.000	2.35
MS21288-17	1.188	.562	1.43	MS21288-34	2.750	2.125	2.43
MS21288-18	1.250	.625	1.47	MS21288-35	2.875	2.250	2.51
MS21288-19	1.312	.688	1.51	MS21288-36	3.000	2.375	2.59
MS21288-20	1.375	.750	1.55				
MS21288-21	1.438	.812	1.59				
MS21288-22	1.500	.875	1.63				

(a) THREAD TO HEAD. MAXIMUM TWO IMPERFECT THREADS. EXCEPT INCOMPLETE THREADS NOT TO ENTER FILLET RADIUS.

- NOTE: (1) SHANK SHALL BE STRAIGHT WITHIN .003 FIR. PER INCH OF BOLT LENGTH.
 (2) THE CONCENTRICITY OF THREAD PD IN RELATION TO THE SHANK SHALL BE WITHIN .006 FIR.
 (3) THE CONCENTRICITY OF THE SHANK IN RELATION TO THE WASHER FACE DIAMETER AND DOUBLE HEXAGON OD SHALL BE WITHIN .011 FIR.

MATERIAL: CORROSION AND HEAT RESISTANT STEEL AMS 5735.
 MANUFACTURING SPECIFICATION: AMS 7478 EXCEPT HEADS TO BE FORMED BY HOT OR COLD UPSETTING.
 PART SUBJECT TO FLUORESCENT PENETRANT INSPECTION PER AMS 2645.
 SURFACE ROUGHNESS: MIL-STD-10 UNLESS OTHERWISE SPECIFIED, SURFACES TO BE 125 MICROINCHES.
 BREAK SHARP EDGES .003-.015 UNLESS OTHERWISE SPECIFIED.
 DIMENSIONS IN INCHES. UNLESS OTHERWISE SPECIFIED: TOLERANCES; LINEAR DIMENSIONS ±.010, ANGULAR DIMENSIONS ±5°
 DO NOT USE UNASSIGNED PART NUMBERS.

This standard has been approved by the BuRep (Department of the Navy) and the Department of the USAF and is mandatory for use by that activity. All other military activities are required to employ this standard where suitable.

P.A. Navy - Wep Other Cust Air Force - ASD	TITLE BOLT, MACHINE - STEEL, DRILLED DOUBLE HEXAGON, EXTENDED WASHER, .190-32 (MIL-S-8879 THREAD)	MILITARY STANDARD MS21288(ASG)
PROCUREMENT SPECIFICATION NONE	SUPERSEDES:	SHEET 1 OF 1

APPROVED 1 May 61 REVISED (A) 23 Oct 61 (B) 17 Sep 63