

USER SYMBOLS:

REVIEWER SYMBOLS:
DLA - IS

"Anyhow/year information is current as of the date of this document. For future coordination of changes to this document, draft circulations should be based on the information in the current DDISS."

This military standard is mandatory for use by all Departments & Agencies of the Department of Defense. Substitutions for all new engineering and design applications and for replacement use shall be made from this document.

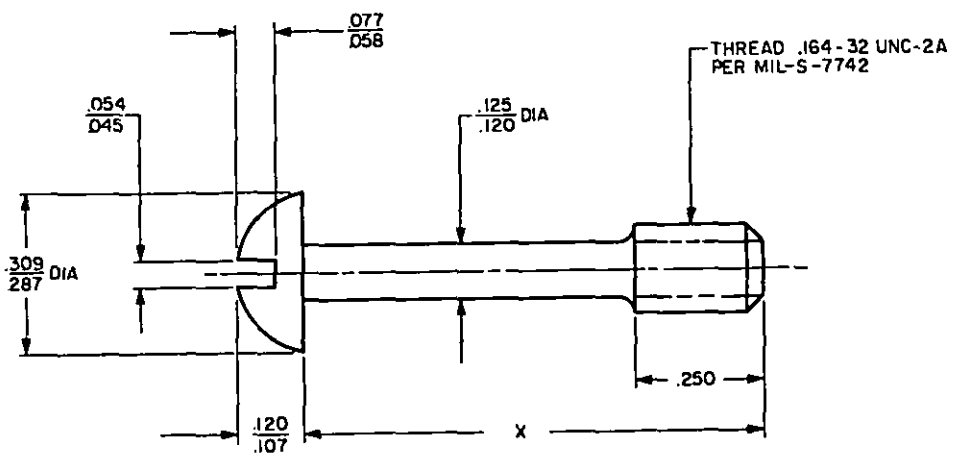
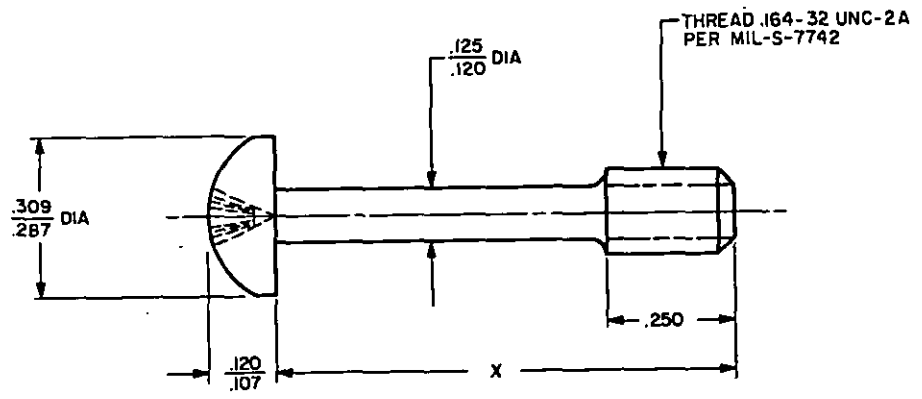

FIG 1. SLOTTED HEAD



ⓑ FIG 2. CROSS-RECESSED HEAD

REQUIREMENTS:

- ⓑ 1. MATERIAL: CARBON STEEL PER ANSI/ASTM A29-79, GRADE 1010.
- ⓑ 2. FINISH: CADMIUM PLATE PER QQ-P-416, TYPE II, CLASS 2.

ⓑ DENOTES CHANGE

P. A. NAVY - AS Other Cust USAF - 99	TITLE	MILITARY STANDARD
	SCREW, EXTERNALLY RELIEVED BODY	MS 25087
PROCUREMENT SPECIFICATION NONE	SUPERSEDES:	SHEET 1 OF 2

APPROVED 4 OCT 54 REVISED ⓐ 5 JUNE 56 ⓑ 28 JUNE 82

TABLE I. PART NUMBERS AND SCREW LENGTHS.

MS PART NO.		X LENGTH (INCHES)
CROSS-RECESSED	SLOTTED	
MS25087-1R	MS25087-1	.875
MS25087-2R	MS25087-2	.718

(B)
(B)

(B) PART NUMBER CODE

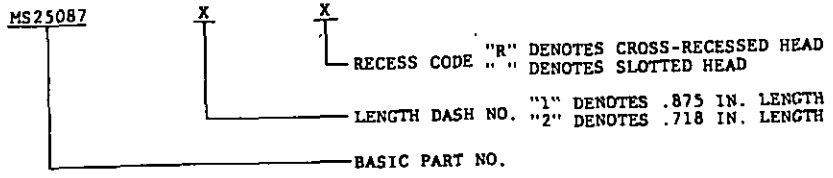

EXAMPLES OF PART NUMBERS:

- (B) MS25087-1R = CARBON STEEL, .875 LONG, CROSS-RECESSED HEAD.
- MS25087-2 = CARBON STEEL, .718 LONG, SLOTTED HEAD.

NOTES:

1. SCREW SHALL BE FREE OF ALL BURRS AND SHARP EDGES.
2. DIMENSIONS IN INCHES.
3. TOLERANCES, UNLESS OTHERWISE SPECIFIED, DECIMALS $\pm .016$.
- (B) 4. CROSS-RECESS SHALL CONFORM TO MS9006 (RECESS DIMENSIONS DETERMINED BY MS9006).
5. REFERENCED DOCUMENTS SHALL BE OF THE ISSUE IN EFFECT ON DATE OF INVITATION FOR BIDS, OR REQUEST FOR PROPOSAL, EXCEPT THAT REFERENCED ADOPTED INDUSTRY DOCUMENTS SHALL GIVE THE DATE OF THE ISSUE ADOPTED.
- (B) 6. SLOTTED HEAD INACTIVE FOR DESIGN AS OF 28 JUNE 1982. USE CROSS-RECESSED HEAD.

USER SYMBOLS:

REVIEWER SYMBOLS:
DLA - IS

"Review/year information is current as of the date of this document. For future coordination of changes in this document, draft circulation should be based on the information in the current 000189."

This military standard is mandatory for use by all Departments & Agencies of the Department of Defense. Solicitation for all new engineering and design applications and for repetitive use shall be made from this document.

APPROVED 4 OCT 54 REVISED (B) FOR CHANGES SEE SHEETS 1 AND 2

P.A. NAVY - AS Other Cust USAF - 99	TITLE	MILITARY STANDARD
	SCREW, EXTERNALLY RELIEVED BODY	MS 25087
PROCUREMENT SPECIFICATION NONE	SUPERSEDES:	SHEET 2 OF 2