

TABLE I

NOMINAL SIZE	(#2) .086	(#4) .112	(#6) .138	(#8) .164	(#10) .190	(1/4) .250	(5/16) .3125	(3/8) .375	
THREADS PER INCH, UNC-2A	56	40	32	32	24	20	18	16	
D BODY DIAMETER	MAX .0860 MIN .0717	MAX .1120 MIN .0925	MAX .1380 MIN .1141	MAX .1640 MIN .1399	MAX .1900 MIN .1586	MAX .2500 MIN .2127	MAX .3125 MIN .2712	MAX .3750 MIN .3287	
A HEAD DIAMETER	MAX .140 MIN .124	MAX .183 MIN .166	MAX .226 MIN .208	MAX .270 MIN .250	MAX .313 MIN .292	MAX .414 MIN .389	MAX .518 MIN .490	MAX .622 MIN .590	
R HEAD SIDE HEIGHT	MAX .062 MIN .055	MAX .079 MIN .072	MAX .096 MIN .089	MAX .113 MIN .106	MAX .130 MIN .123	MAX .170 MIN .161	MAX .211 MIN .201	MAX .253 MIN .242	
O TOTAL HEAD HEIGHT	MAX .083 MIN .070	MAX .107 MIN .094	MAX .132 MIN .118	MAX .156 MIN .141	MAX .180 MIN .165	MAX .237 MIN .219	MAX .295 MIN .276	MAX .355 MIN .333	
J SLOT WIDTH	MAX .031 MIN .023	MAX .039 MIN .031	MAX .048 MIN .039	MAX .054 MIN .045	MAX .060 MIN .050	MAX .075 MIN .064	MAX .084 MIN .072	MAX .094 MIN .081	
T SLOT DEPTH	MAX .030 MIN .022	MAX .038 MIN .030	MAX .045 MIN .035	MAX .065 MIN .054	MAX .075 MIN .064	MAX .102 MIN .087	MAX .130 MIN .110	MAX .154 MIN .134	
E DRILL LOCATION	NOM .026	NOM .035	NOM .043	NOM .043	NOM .043	NOM .062	NOM .078	NOM .094	
DRILLED HOLE SIZE	NOM .031	NOM .037	NOM .046	NOM .046	NOM .046	NOM .062	NOM .070	NOM .070	
R RADIUS	MAX .013	MAX .017	MAX .021	MAX .025	MAX .029	MAX .038	MAX .047	MAX .056	
TENSILE STRENGTH, LB-MIN	300	480	730	1120	1400	2540	4190	6200	
L LENGTH	TOLERANCE	DASH NO.	DASH NO.	DASH NO.	DASH NO.	DASH NO.	DASH NO.	DASH NO.	DASH NO.
.125		201	211	224	239	276			
.188		202	212	225	240				
.250		203	213	226	241				
.312		204	214	227	242				
.375	+0 -.031	205	215	228	243	261	277	292	307
.438		206	216	229	244	262	278	293	
.500		207	217	230	245	263	279	294	
.625		208	218	231	246	264	280	295	
.750		209	219	232	247	265	281	296	309
.875		210	220	233	248	266	282	297	310
1.000		221	234	249	267	283	298	311	
1.250		222	235	250	268	284	299	312	
1.500	+0 -.062		223	236	251	269	285	300	313
1.750			237	252	270	286	301	314	
2.000			238	253	271	287	302	315	
2.250			254	272	288	303	316		
2.500	+0 -.094			255	273	289	304	317	318
2.750				256	274	290	305	318	
3.000				257	275	291	306	319	

REVIEW: E. M., EA. S. AV. M. AT
USER: SM, CL, MA, YO, PA, WY, MC

Every standard is approved for use by all Departments and Agencies
Department of Defense. Selection for all use engineering and design
applications and for repetitive use shall be made from this document, unless otherwise specified.

(B) ENTIRE STANDARD REVISED

P.A. WC Other Cust AS 82	TITLE SCREW, MACHINE-DRILLED FILLISTER HEAD, SLOTTED, CORROSION RESISTING STEEL, PASSVATED, UNC-2A	MILITARY STANDARD MS35275
PROCUREMENT SPECIFICATION FF-S-92	SUPERSEDES: BCPX1.5, BCPX2.5, BCPX7.1 and in part AN500, MS35361, MS35366 and BCGX3.1	SHEET 1 OF 4

APPROVED 9 FEB 1954 REVISED (A) 29 JULY 1965 (B) 14 JUN 1976

NOTES:

1. **MATERIAL:** Steel, Corrosion Resisting, in accordance with Fed. Std. No. 66; AISI 302, 303, 304, 305, 316, or 384 (developed for cold heading), and having minimum ultimate tensile strength of 80,000 PSI.
2. **TREATMENT:** Passivation shall be in accordance with QQ-P-35.
3. **MAGNETIC PERMEABILITY:** These fasteners have a magnetic permeability of 2.0 maximum (air = 1.0) for a field strength of H = 200 oersteds using a magnetic indicator per MIL-I-17214.
4. **THREADS:** The threads shall be in accordance with Screw-Thread Standards for Federal Services, Handbook H-28.
5. **THREAD LENGTH:** Screws 2.00 inches long and shorter shall have complete threads extending to within two threads of the head, or closer if practicable. Longer screws shall have a minimum thread length of 1.50 inches.
6. **DIMENSIONS:** All dimensions are in inches unless otherwise specified.
7. **PART NUMBER:** The MS part number consists of the MS number, plus the dash number.
Example: MS35275-201
8. Drilled hole is to be approximately at right angles to the slot and may be permitted to break through the bottom of the slot. All sharp edges shall be removed.
9. Referenced documents shall be of the issue in effect on date of invitations for bid.
10. For design feature purposes, this standard takes precedence over procurement documents referred herein.

REVIEW: EL, ME, EA, IS, AM, ML, AT
USER: SA, CL, MA, YD, PA, WY, MC

This military standard is approved for use by all Departments and Agencies of the Department of Defense. Selection for all new engineering and design applications and for repetitive use shall be made from this document, when available.

SHEET 1.

APPROVED 9 FEB 1954 REVISED (A) 29 JUL 1965 (B) FOR CHANGES

P.A. WC Other Cust AS 82	TITLE SCREW, MACHINE-DRILLED FILLISTER HEAD, SLOTTED, CORROSION RESISTING STEEL, PASSIVATED, UNC-2A	MILITARY STANDARD MS35275
PROCUREMENT SPECIFICATION FF-S-92	SUPERSEDES: BCFX1.5, BCFX2.5, BCFX7.1 and in part ANS00, MS35361, MS35366 and BCCX3.1	SHEET 2 OF 4

**TABLE II
INTERCHANGEABILITY TABLE**

FED. SUP CLASS
5305

The screws covered by the dash numbers given in original issue of this standard and AN500 in part, are cancelled/inactivated after the approval date of revision A indicated on this document. Use the dash numbers given in the preceding sheets. The cancelled screws cannot always replace the new screws and should be used until existing stocks are depleted. Use only the new screws for design and replacement. Replacement shall be in accordance with this table.

PART NUMBERS			PART NUMBERS		
CANCELLED		SUPERSEDED BY	CANCELLED		SUPERSEDED BY
MS35275-1		MS35275-201	MS35275-81	AN500-AD10-6	MS35275-261
-2	AN500-AD2-3	-202	-62	-AD10-7	-262
-3	-AD2-4	-203	-63	-AD10-8	-263
-4	-AD2-5	-204	-64	-AD10-10	-264
-5	-AD2-6	-205	-65	-AD10-12	-265
-6	-AD2-7	-206	-66	-AD10-14	-266
-7	-AD2-8	-207	-67	-AD10-16	-267
-8	-AD2-10	-208		-AD10-18	No Replacement
-9	-AD2-12	-209	-68	-AD10-20	-268
-10		-210		-AD10-22	No Replacement
	AD3-3 thru AD3-8	No Replacement	-69	-AD10-24	-269
	-AD3-10	No Replacement	-70	-AD10-28	-270
	-AD3-12	No Replacement	-71	-AD10-32	-271
-11		-211	-72		-272
-12	-AD4-3	-212	-73	-AD10-40	-273
-13	-AD4-4	-213	-74		-274
-14	-AD4-5	-214	-75	-AD10-48	-275
-15	-AD4-6	-215	-76		-276
-16	-AD4-7	-216	-77	-AD416-6	-277
-17	-AD4-8	-217	-78	-AD416-7	-278
-18	-AD4-10	-218	-79	-AD416-8	-279
-19	-AD4-12	-219	-80	-AD416-10	-280
-20		-220	-81	-AD416-12	-281
-21		-221	-82	-AD416-14	-282
-22		-222	-83	-AD416-16	-283
-23		-223		-AD416-18	No Replacement
	AD5-3 thru AD5-8	No Replacement	-84	-AD416-20	-284
	-AD5-10	No Replacement	-85	-AD416-22	No Replacement
	-AD5-12	No Replacement	-86	-AD416-24	-285
-24		-224	-87	-AD416-28	-286
-25	-AD6-3	-225	-88	-AD416-32	-287
-26	-AD6-4	-226	-89		-288
-27	-AD6-5	-227	-90	-AD416-40	-289
-28	-AD6-6	-228	-91		-290
-29	-AD6-7	-229	-92	-AD416-48	-291
-30	-AD6-8	-230	-93	-AD516-6	-292
-31	-AD6-10	-231	-94	-AD516-7	-293
-32	-AD6-12	-232	-95	-AD516-8	-294
-33	-AD6-14	-233	-96	-AD516-10	-295
-34	-AD6-16	-234	-97	-AD516-12	-296
	-AD6-18	No Replacement	-98	-AD516-14	-297
-35	-AD6-20	-235	-99	-AD516-16	-298
	-AD6-22	No Replacement		-AD516-18	No Replacement
-36	-AD6-24	-236	-100	-AD516-20	-299
-37	-AD6-28	-237	-101	-AD516-22	No Replacement
-38	-AD6-32	-238	-102	-AD516-24	-300
-39		-239	-103	-AD516-28	-301
-40		-240	-104	-AD516-32	-302
-41	-AD8-4	-241	-105		-303
-42	-AD8-5	-242	-106	-AD516-40	-304
-43	-AD8-6	-243			-305
-44	-AD8-7	-244		-AD516-48	-306
-45	-AD8-8	-245		-AD616-6	No Replacement
-46	-AD8-10	-246		-AD616-7	No Replacement
-47	-AD8-12	-247	-107	-AD616-8	-307
-48	-AD8-14	-248	-108	-AD616-10	-308
-49	-AD8-16	-249	-109	-AD616-12	-309
	-AD8-18	No Replacement	-110	-AD616-14	-310
-50	-AD8-20	-250	-111	-AD616-16	-311
	-AD8-22	No Replacement		-AD616-18	No Replacement
-51	-AD8-24	-251	-112	-AD616-20	-312
-52	-AD8-28	-252		-AD616-22	No Replacement
-53	-AD8-32	-253	-113	-AD616-24	-313
-54		-254	-114	-AD616-28	-314
-55		-255	-115	-AD616-32	-315
-56		-256	-116		-316
-57		-257	-117	-AD616-40	-317
-58		-258	-118		-318
-59	-AD10-4	-259	-119	-AD616-48	-319
-60	-AD10-5	-260			

REVIEWER: EL, ME, EA, IS, RA, MI, AT
USER: SA, OL, ML, YO, PA, WV, MC

This military standard is approved for use by all Departments and Agencies of the Department of Defense. Selection for all new engineering and design applications and for repetitive use shall be made from this document, when applicable.

APPROVED FEB 9, 1954 REVISED (A) 29 JUL 1965 (B) FOR CHANGES SEE SHEET 1.

P.A.	WC	TITLE	MILITARY STANDARD
Other Cust	AS	SCREW, MACHINE-DRILLED FILLISTER HEAD, SLOTTED,	MS 35275
	82	CORROSION RESISTING STEEL, PASSIVATED, UNC-2A	
PROCUREMENT SPECIFICATION FF-S-92		SUPERSEDES: BCFX1.5, BCFX2.5, BCFY1.7 and in part AN500, MS35361, MS35366 and BCGX3.1.	SHEET 3 OF 4

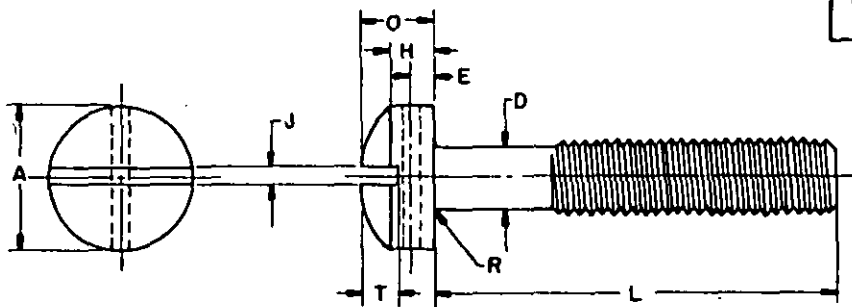

TABLE III
METRIC TRANSLATION OF TABLE I

NOMINAL SIZE	MM	2.184	2.845	3.505	4.166	4.826	6.350	7.938	9.525
PITCH		.45	.64	.79	.79	1.06	1.27	1.41	1.59
D BODY DIAMETER	MAX MIN	2.184 1.821	2.845 2.350	3.505 2.898	4.166 3.553	4.826 4.028	6.350 5.403	7.938 6.888	9.525 8.349
A HEAD DIAMETER	MAX MIN	3.556 3.150	4.648 4.216	5.740 5.283	6.858 6.350	7.950 7.417	10.516 9.881	13.157 12.446	15.799 14.986
H HEAD SIDE HEIGHT	MAX MIN	1.575 1.397	2.007 1.829	2.438 2.261	2.870 2.692	3.302 3.124	4.318 4.089	5.359 5.105	6.426 6.147
O TOTAL HEAD HEIGHT	MAX MIN	2.108 1.778	2.718 2.388	3.353 2.997	3.962 3.581	4.572 4.191	6.020 5.563	7.493 7.010	9.017 8.458
J SLOT WIDTH	MAX MIN	.787 .584	.991 .787	1.219 .991	1.372 1.143	1.524 1.270	1.905 1.626	2.134 1.829	2.388 2.057
T SLOT DEPTH	MAX MIN	.762 .559	.965 .762	1.143 .889	1.651 1.372	1.905 1.626	2.591 2.210	3.302 2.794	3.912 3.404
E DRILL LOCATION	NOM	.660	.889	1.092	1.092	1.092	1.575	1.981	2.388
DRILLED HOLE SIZE	NOM	.787	.940	1.168	1.168	1.168	1.575	1.778	1.778
R RADIUS	MAX	.330	.432	.533	.635	.737	.965	1.194	1.422
TENSILE STRENGTH, KN-MIN		1.344	2.151	3.272	5.020	6.275	11.384	18.780	27.789
L LENGTH	TOLERANCE	DASH NO.	DASH NO.	DASH NO.	DASH NO.	DASH NO.	DASH NO.	DASH NO.	DASH NO.
3.175		201	211	224	239				
4.775		202	212	225	240	258			
6.350		203	213	226	241	259			
7.925		204	214	227	242	260	276		
9.525		205	215	228	243	261	277	292	
11.125	+0	206	216	229	244	262	278	293	
12.700	-.787	207	217	230	245	263	279	294	307
15.875		208	218	231	246	264	280	295	308
19.050		209	219	232	247	265	281	296	309
22.225		210	220	233	248	266	282	297	310
25.400			221	234	249	267	283	298	311
31.750			222	235	250	268	284	299	312
38.100	+0		223	236	251	269	285	300	313
44.450	-1.575			237	252	270	286	301	314
50.800				238	253	271	287	302	315
57.150					254	272	288	303	316
63.500	+0				255	273	289	304	317
69.850	-2.388				256	274	290	305	318
76.200					257	275	291	306	319

NOTE: All dimensions are in millimetres (mm), unless otherwise specified, and are based on an approximate conversion factor of 25.4mm equals one inch.

U.S. GOVERNMENT PRINTING OFFICE: 1976-603-766/5027

APPROVED 9 FEB 1954 REVISED (A) 29 JUL 1985 (B) FOR CHANGES SEE SHEET 1.

P.A. WC Other Cust AS 82	TITLE SCREW, MACHINE-DRILLED FILLISTER HEAD, SLOTTED, CORROSION RESISTING STEEL, PASSNATED, UNC-2A	MILITARY STANDARD MS35275
PROCUREMENT SPECIFICATION PS-S-92	SUPERSEDES: BCFX1.5, BCFX2.5, BCFX7.1 and in part AN500, MS35361, MS35366 and BCGX3.1	SHEET 4 OF 4

REVIEW: EL, ME, EA, IS, AM, MI, AT
USER: SH, GL, ML, YD, PA, WY, MC

This military standard is approved for use by all Departments and Agencies of the Department of Defense. Selection for all new engineering and design applications and for repetitive use shall be made from this document, when available.