

MILITARY SPECIFICATION SHEET

SCREW, CAP, HEXAGON HEAD (FINISHED HEXAGON BOLT),
STEEL, CORROSION RESISTING, PASSIVATED, UNC-2A

This specification is approved for use by all Departments
and Agencies of the Department of Defense.

The requirements for acquiring the product described herein shall consist
of this specification sheet and the issue of the following specification listed
in that issue of the Department of Defense Index of Specifications and
Standards (DoDISS) specified in the solicitation: FF-S-85.

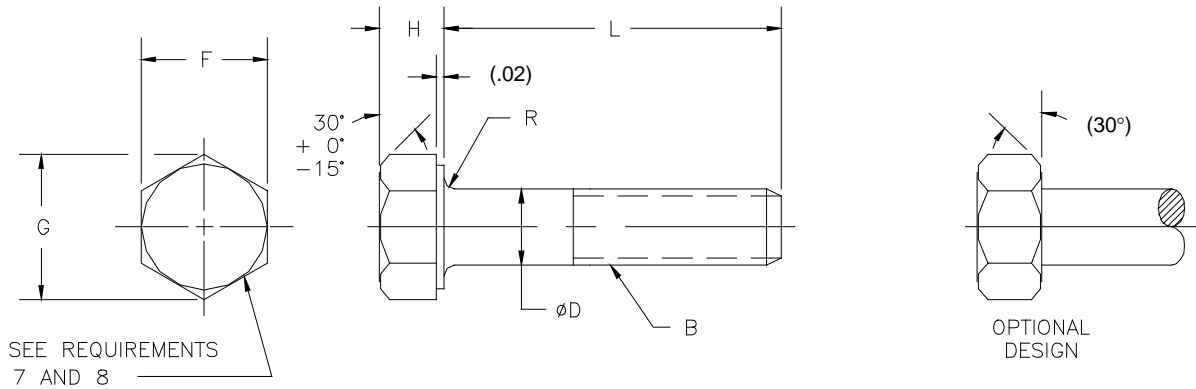

(E) Entire document revised

MS35307E

Table I. Dimensions and Dash Numbers.

Nominal Size		.2500	.3125	.3750	.4375	.5000	.5625	.6250	.7500	.8750	1.0000	1.1250	1.2500
B Threads Per Inch UNC-2A		20	18	16	14	13	12	11	10	9	8	7	7
Ø D Body Diameter	Max	.2500	.3125	.3750	.4375	.5000	.5625	.6250	.7500	.8750	1.0000	1.1250	1.2500
	Min	.2450	.3065	.3690	.4305	.4930	.5545	.6170	.7410	.8660	.9900	1.1140	1.2390
F Width across flats	Max	.4375	.5000	.5625	.6250	.7500	.8125	.9375	1.1250	1.3125	1.5000	1.6875	1.8750
	Min	.4280	.4890	.5510	.6120	.7360	.7980	.9220	1.1000	1.2850	1.4690	1.6310	1.8120
G Width across corners	Max	.505	.577	.650	.722	.866	.938	1.083	1.299	1.516	1.732	1.949	2.165
	Min	.488	.557	.628	.698	.840	.910	1.051	1.254	1.465	1.675	1.859	2.066
H ₁ Head Height	Max	.163	.211	.243	.291	.323	.371	.403	.483	.563	.627	.718	.813
	Min	.150	.195	.226	.272	.302	.348	.378	.455	.531	.591	.658	.749
R Radius	Max	.025	.025	.025	.025	.025	.045	.045	.045	.065	.095	.095	.095
	Min	.015	.015	.015	.015	.015	.020	.020	.020	.040	.060	.060	.060
Tensile Strength Lbs-Min		2,540	4,190	6,200	8,500	11,300	14,500	18,050	23,350	32,300	42,400	53,400	67,800
L Length	Tolerance	Dash No.	Dash No.	Dash No.	Dash No.	Dash No.	Dash No.	Dash No.	Dash No.	Dash No.	Dash No.	Dash No.	Dash No.
.375		301	327	353									
.438		302	328	354	379								
.500		303	329	355	380	404							
.562		304	330	356	381	405	430						
.625	+0	305	331	357	382	406	431	455					
.750	-.031	306	332	358	383	407	432	456	479				
.875		307	333	359	384	408	433	457	480	502			
1.000		308	334	360	385	409	434	458	481	503	524		
1.125		309	335	361	386	410	435	459	482	504	525	545	
1.250		310	336	362	387	411	436	460	483	505	526	546	565
1.375		311	337	363	388	412	437	461	484	506	527	547	566
1.500		312	338	364	389	413	438	462	485	507	528	548	567
1.750	+0	313	339	365	390	414	439	463	486	508	529	549	568
2.000	-.062	314	340	366	391	415	440	464	487	509	530	550	569
2.250		315	341	367	392	416	441	465	488	510	531	551	570
2.500		316	342	368	393	417	442	466	489	511	532	552	571
2.750	+0	317	343	369	394	418	443	467	490	512	533	553	572
3.000	-.094	318	344	370	395	419	444	468	491	513	534	554	573
3.250		319	345	371	396	420	445	469	492	514	535	555	574
3.500		320	346	372	397	421	446	470	493	515	536	556	575
3.750		321	347	373	398	422	447	471	494	516	537	557	576
4.000		322	348	374	399	423	448	472	495	517	538	558	577
4.250		323	349	375	400	424	449	473	496	518	539	559	578
4.500		324	350	376	401	425	450	474	497	519	540	560	579
4.750		325	351	377	402	426	451	475	498	520	541	561	580
5.000		326	352	378	403	427	452	476	499	521	542	562	581
5.500						428	453	477	500	522	543	563	582
6.000						429	454	478	501	523	544	564	583

REQUIREMENTS:

1. **MATERIAL:** Austenitic Corrosion-Resistant Steel screws shall be manufactured from Type 304 (UNS S30400), Type 304L (UNS S30403), Type 305 (UNS S30500), Type 316 (UNS S31600), Type 316L CRES (UNS S31603), Type 384 (UNS S38400), or Type XM-7 (UNS S30430) in accordance with the chemical compositions specified in ASTM F 593. (See Material Identification Marking and Material Code).
2. **FINISH:** Passivate in accordance with QQ-P-35.

3. MECHANICAL PROPERTIES: The minimum tensile strength in load pounds, indicated in Table I is based on 80,000 PSI Minimum Tensile Strength for diameters through .625 inch and 70,000 PSI Minimum Tensile Strength for diameters over .625 inch. The yield strength, based on .2 percent offset, shall be 30,000 psi minimum. The minimum hardness shall be HRB 80 for diameters through .625 inch and HRB 74 for diameters over .625 inch.
4. MAGNETIC PERMEABILITY: When specified, screws shall have a magnetic permeability of less than 2.0 maximum (air = 1.0) for a field strength H=200 Oersteds using a magnetic permeability indicator per ASTM A 342. Note: Cold working screws may not be capable of meeting permeability and strength requirements simultaneously.
5. THREADS: Screw threads shall be Unified external threads Class 2A UNC in accordance with FED-STD-H28/2. Acceptability of screw threads shall be in accordance with FED-STD-H28/20.
6. THREAD LENGTH: Minimum thread length shall be twice the diameter plus .250 inch. The tolerance shall be plus .188 inch or 2.500 threads, whichever is greater. On screws that are too short for minimum thread lengths, the distance from the bearing surface of the head to the first complete thread shall not exceed the length of 2.500 threads for sizes up to and including 1.000 inch and 3.500 threads for sizes larger than 1.000 inch.
7. MANUFACTURER IDENTIFICATION MARKING: Screws shall be permanently marked with the manufacturer's symbol. Marking shall be raised or depressed on the screw head.
8. MATERIAL IDENTIFICATION MARKING: Heads shall be marked in accordance with MIL-HDBK-131. Additionally, Type 316 or Type 316L CRES screws shall be permanently marked "316". Markings shall be raised or depressed on the screw head at manufacturer's option.
9. MATERIAL CODE:
 - For 300 Series CRES - No code after dash number indicates any 300 Series Austenitic Corrosion-Resistant Steel listed in material requirement.
 - For Type 316 or Type 316L CRES - "S316" after dash number indicates Austenitic Corrosion-Resistant Steel Type 316 or Type 316L.
10. PART NUMBER: The part number shall consist of the basic MS number, followed by a dash number from Table I and a material code (if applicable).

EXAMPLES: MS35307-301 indicates Screw, Cap, Hexagon Head, 300 Series Austenitic Corrosion-Resistant Steel, Passivated; .2500-20 UNC-2A Nominal Thread Size, .375 Length
MS35307-301S316 indicates Screw, Cap, Hexagon Head, Austenitic Corrosion-Resistant Steel Type 316 or Type 316L, Passivated; .2500-20 UNC-2A Nominal Thread Size, .375 Length

NOTES:

1. All dimensions are in inches.
2. Interpret drawing in accordance with ASME Y14.5M.
3. In the event of a conflict between the text of this document and the references cited herein, the text of this document shall take precedence.
4. Unless otherwise specified, issues of referenced documents are those in effect at the time of solicitation.
5. MS35307 Hexagon Head Cap Screws manufactured prior to 25 April 1997 may be used until stock is depleted.

MS35307E

The screws covered by dash numbers given in original issue of this document are canceled after 7 May 63. Use dash numbers given in the preceding sheets of this document. The canceled screws cannot always replace the new screws and should be used until existing stock are depleted. Use only the new screws for design and replacement. Replacement should be in accordance with this table.

INTERCHANGEABILITY TABLE

Table II

DASH NUMBER		DASH NUMBER		DASH NUMBER		DASH NUMBER		DASH NUMBER	
CANCELED	NEW	CANCELED	NEW	CANCELED	NEW	CANCELED	NEW	CANCELED	NEW
MS35307	MS35307	MS35307	MS35307	MS35307	MS35307	MS35307	MS35307	MS35307	MS35307
1	301	61	361	121	421	181	481	241	541
2	302	62	362	122	422	182	482	242	542
3	303	63	363	123	423	183	483	243	543
4	304	64	364	124	424	184	484	244	544
5	305	65	365	125	425	185	485	245	545
6	306	66	366	126	426	186	486	246	546
7	307	67	367	127	427	187	487	247	547
8	308	68	368	128	428	188	488	248	548
9	309	69	369	129	429	189	489	249	549
10	310	70	370	130	430	190	490	250	550
11	311	71	371	131	431	191	491	251	551
12	312	72	372	132	432	192	492	252	552
13	313	73	373	133	433	193	493	253	553
14	314	74	374	134	434	194	494	254	554
15	315	75	375	135	435	195	495	255	555
16	316	76	376	136	436	196	496	256	556
17	317	77	377	137	437	197	497	257	557
18	318	78	378	138	438	198	498	258	558
19	319	79	379	139	439	199	499	259	559
20	320	80	380	140	440	200	500	260	560
21	321	81	381	141	441	201	501	261	561
22	322	82	382	142	442	202	502	262	562
23	323	83	383	143	443	203	503	263	563
24	324	84	384	144	444	204	504	264	564
25	325	85	385	145	445	205	505	265	565
26	326	86	386	146	446	206	506	266	566
27	327	87	387	147	447	207	507	267	567
28	328	88	388	148	448	208	508	268	568
29	329	89	389	149	449	209	509	269	569
30	330	90	390	150	450	210	510	270	570
31	331	91	391	151	451	211	511	271	571
32	332	92	392	152	452	212	512	272	572
33	333	93	393	153	453	213	513	273	573
34	334	94	394	154	454	214	514	274	574
35	335	95	395	155	455	215	515	275	575
36	336	96	396	156	456	216	516	276	576
37	337	97	397	157	457	217	517	277	577
38	338	98	398	158	458	218	518	278	578
39	339	99	399	159	459	219	519	279	579
40	340	100	400	160	460	220	520	280	580
41	341	101	401	161	461	221	521	281	581
42	342	102	402	162	462	222	522	282	582
43	343	103	403	163	463	223	523	283	583
44	344	104	404	164	464	224	524		
45	345	105	405	165	465	225	525		
46	346	106	406	166	466	226	526		
47	347	107	407	167	467	227	527		
48	348	108	408	168	468	228	528		
49	349	109	409	169	469	229	529		
50	350	110	410	170	470	230	530		
51	351	111	411	171	471	231	531		
52	352	112	412	172	472	232	532		
53	353	113	413	173	473	233	533		
54	354	114	414	174	474	234	534		
55	355	115	415	175	475	235	535		
56	356	116	416	176	476	236	536		
57	357	117	417	177	477	237	537		
58	358	118	418	178	478	238	538		
59	359	119	419	179	479	239	539		
60	360	120	420	180	480	240	540		

Military Interests:

Custodians:

Army - AR
Navy - AS
Air Force - 99

Preparing activity:

DLA - IS

(Project 5305-2127)

Reviewer:

Army - AV, AT, EA, ER, GL, ME, MI
Navy - SH, OS, YD1
National Security Agency - NSA