

MS SPECIFICATION SHEET

WASHER, LOCK, FLAT-EXTERNAL TOOTH

Reactivated after 2 February 2004 and may be used for new and existing designs and acquisitions.

This Specification is approved for use by all Departments and Agencies of the Department of Defense.

The requirements for acquiring the product described herein shall consist of this MS specification sheet and ASME B18.21.1

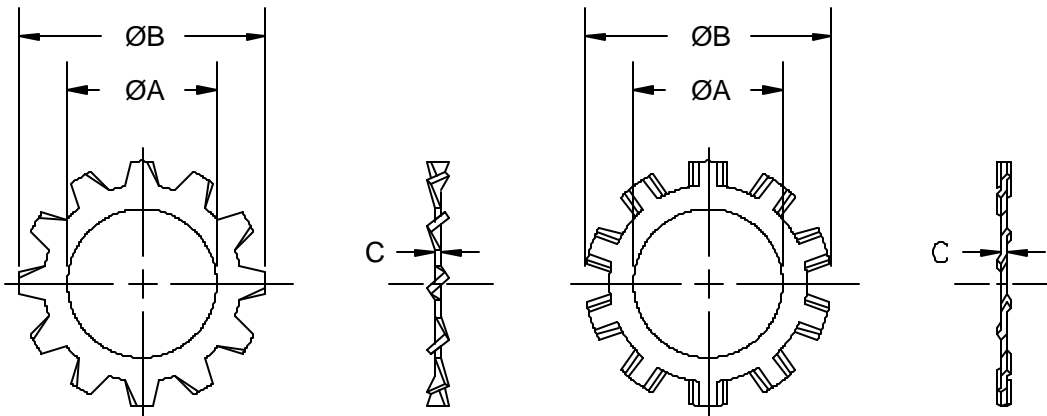

ACCEPTABLE DESIGNS

Figure 1. Lock washer.

MS35335G

TABLE I. Washer sizes and dimensions.

NOMINAL SIZE	ØA INSIDE DIAMETER		ØB OUTSIDE DIAMETER		C THICKNESS		CARBON STEEL	CORROSION RESISTANT STEEL	TIN-BRASS OR PHOSPHOR BRONZE OPTIONAL	
	MAX	MIN	MAX	MIN	MAX	MIN	ZINC PLATE	PASSIVATED	UNCOATED	
							DASH NO.	DASH NO.	DASH NO.	
#4	.112	.123	.115	.260	.245	.019	.015	29	57	85
#6	.138	.150	.141	.320	.305	.022	.016	30	58	86
#8	.164	.176	.168	.381	.365	.023	.018	31	59	87
#10	.190	.204	.195	.410	.395	.025	.020	32	60	88
1/4	.250	.267	.256	.510	.494	.028	.023	33	61	89
5/16	.312	.332	.320	.610	.588	.034	.028	34	62	90
3/8	.375	.398	.384	.694	.670	.040	.032	35	63	91
7/16	.438	.464	.448	.760	.740	.040	.032	36	64	92
1/2	.500	.530	.513	.900	.880	.045	.037	37	65	93
9/16	.562	.596	.576	.985	.960	.045	.037	38	66	94
5/8	.625	.663	.641	1.070	1.045	.050	.042	39	67	95
3/4	.750	.795	.768	1.260	1.220	.055	.047	40	68	96
7/8	.875	.927	.897	1.410	1.380	.060	.052	41	69	97
1	1.000	1.060	1.025	1.620	1.590	.067	.059	42	70	98

REQUIREMENTS:

MATERIAL: Carbon, Steel, UNS G10500 – UNS G10640, hardness 40 - 50 HRC.
Corrosion resistant steel, UNS S41000.
Tin-brass, UNS C42500.
Phosphor Bronze, temper H04, ASTM B159, UNS C51000.

PROTECTIVE COATING: Carbon steel - Mechanically deposited Zinc in accordance with SAE-AMS-C-81562.
Corrosion resistant steel - Passivate in accordance with SAE-AMS-QQ-P-35.

PART NUMBER: The MS part number consists of the MS number, plus the dash number.
Example: MS35335-29

PACKAGING: Packaging shall be in accordance with ASTM D3951.

All dimensions are inches, unless otherwise specified.

The number of teeth shall be at the option of the supplier.

These lock washers shall be used with fasteners having heads large enough to contact lock washer teeth.

In the event of a conflict between the text of this standard and the reference cited herein, the text of standard shall take precedence.

CHANGES FROM PREVIOUS ISSUE. Marginal notations are not used to identify changes with respect to the previous issue due to the extent of the changes.

Custodians:

Army - AT
Navy - AS
Air Force - 99

Preparing activity:

DLA - IS

(Project 5310-2711)

Review activities:

Army - AV, CR, CR4, GL, MI
Navy - MC, OS, YD
Air Force - 71