

MS 35446C  
 15 December 1989  
SUPERSEDING  
 MS 35446B  
 10 FEBRUARY 1961

MILITARY SPECIFICATION SHEET

TERMINAL, LUG, SOLDER TYPE, COPPER TUBING, ONE HOLE

This specification is approved for use by all Departments and Agencies of the Department of Defense.

The requirements for acquiring the product described herein shall consist of this specification sheet and the issue of the following specification listed in the issue of the Department of Defense Index of Specifications and Standards (DoDISS) specified in the solicitation: MTL-T-15659.

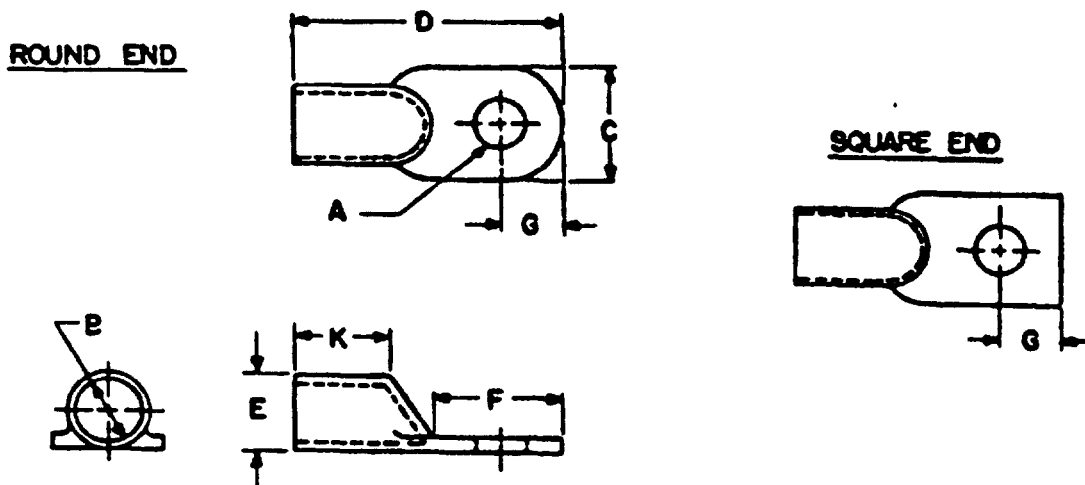

Ⓒ Denotes Change

MS 35446C  
TABLE I. Dimensional data.

RND END DASH NO	SQ END DASH NO	WIRE SIZE AWG NOM	STUD SIZE	A HOLE $\phi$		B	C	D	E	F	G	K
				MIN	MAX							
1	11	10	8	.167	.179	.143	1/4	15/16	3/16	15/32	3/16	11/32
2	12	8	10	.193	.205	.186	3/8	1-1/32	1/4	1/2	7/32	11/32
3	13	6	10	.193	.205	.238	7/16	1/7/32	5/16	19/32	1/4	3/8
4	14	4	1/4	.258	.285	.289	17/32	1-3/8	3/8	11/16	9/32	7/16
5	15	2	1/4	.258	.285	.347	5/8	1-1/2	7/16	3/4	11/32	1/2
6	16	0	5/16	.320	.347	.401	3/4	1-3/4	1/2	13/16	13/32	9/16
7	17	00	3/8	.383	.410	.460	13/16	2.0	9/16	15/16	7/16	11/16
8	18	000	3/8	.383	.410	.519	29/32	2-1/8	5/8	1.0	1/2	25/32
9	19	0000	3/8	.383	.410	.559	1.0	2-3/8	11/16	1-5/32	17/32	27/32
10	20	250MCM	3/8	.383	.410	.660	1-3/16	2-41/64	13/16	1-1/4	5/8	31/32
21	28	150MCM	1/2	.510	.537	.651	1-3/16	2-5/8	13/16	1-1/4	5/8	
22	29	200MCM	1/2	.510	.537	.776	1-25/64	3-1/8	15/16	1-11/16	3/4	TO
23	30	300MCM	1/2	.510	.537	.820	1-1/2	3-7/16	1.0	1-3/4	13/16	SUIT
24	31	400MCM	5/8	.656	.783	.881	1-9/16	4-5/32	1-1/16	2-3/32	15/16	MFR
25	32	500MCM	5/8	.656	.783	.944	1-43/64	4-15/32	1-1/8	2-7/32	15/16	DESIGN
26	33	650MCM	3/4	.781	.808	1.084	1-31/32	5-1/16	1-5/16	2-1/2	1-1/8	
27	34	800MCM	7/8	.906	.933	1.210	2-1/8	5-3/8	1-7/16	2-1/2	1-1/8	

REQUIREMENTS:

1. MATERIAL: Electrolytic Copper Tubing in accordance with ASTM B188.
2. FINISH: Electrodeposited tin over entire surface in accordance with MIL-T-10727. Minimum thickness 0.0005. Remove all burrs.
3. DIMENSIONS AND TOLERANCE: Dimensions are in inches. Unless otherwise specified, tolerance is  $\pm .015$ .
4. The MS part number consists of the MS number plus the Dash number.
5. In the event of a conflict between the text of this Military Specification Sheet and the references cited herein, the text of this Military Specification Sheet shall take precedence.
6. Referenced Government (or non-government) documents of the issue listed in the Department of Defense Index of Specifications and Standards (DoDISS) specified in the solicitation form a part of this Military Specification Sheet to the extent specified herein.

Custodian:  
Army - AR  
Navy - SH  
Air Force - 85

Preparing Activity:  
Army - AR

Project Number 5940-1053

Review Activities:  
Army - AV, MI  
Air Force - 11, 99  
DLA - DGSC

User Activities:  
Navy - AS, MC