

USER ACTIVITIES
NAVY - MC

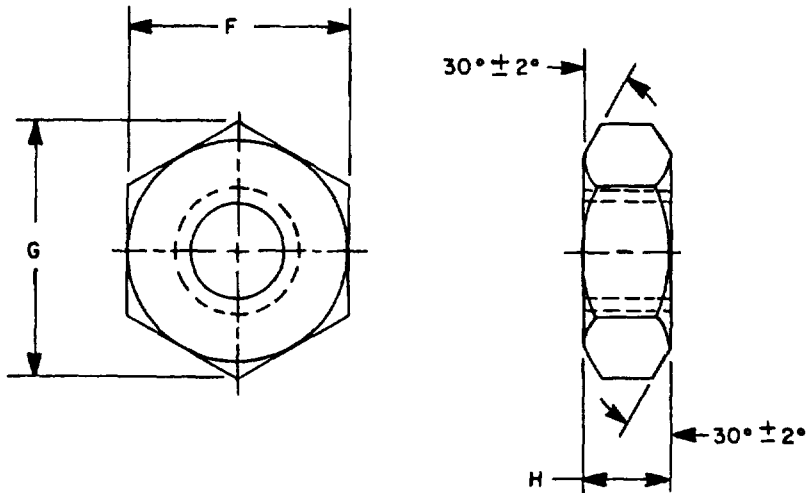

TABLE I. DASH NUMBERS AND DIMENSIONS.

DASH NO	THREAD	WIDTH ACROSS FLATS			WIDTH ACROSS CORNERS		THICKNESS		
		F			G		H		
		NOM	MAX	MIN	MAX	MIN	NOM	MAX	MIN
01	.086-56UNC-2B	3/16	.187	.180	.217	.205	1/16	.066	.057
02	.138-32UNC-2B	5/16	.312	.302	.361	.344	7/64	.114	.102
03	.164-32UNC-2B	11/32	.343	.332	.397	.378	1/8	.130	.117

REVIEW ACTIVITIES
ARMY - EA, MI
DLA - IS
NSA - NS

REQUIREMENTS

- MATERIAL** STEEL, CARBON SHALL BE IN ACCORDANCE WITH PROCUREMENT SPECIFICATION
- FINISH** CARBON STEEL NUTS SHALL BE ZINC COATED IN ACCORDANCE WITH QQ-Z-325, TYPE II, CLASS 2
- PART NUMBER** THE PART NUMBER CONSISTS OF THE BASIC MS SHEET NUMBER FOLLOWED BY A DASH NUMBER TAKEN FROM TABLE I

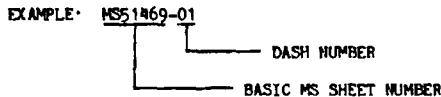

MS51469-01 INDICATES - NUT, PLAIN, HEXAGON, (MACHINE SCREW), CARBON STEEL, ZINC COATED, 086-56UNC-2B

NOTES.

- ALL DIMENSIONS ARE IN INCHES.
- REFERENCED DOCUMENTS SHALL BE OF THE ISSUE IN EFFECT ON THE DATE OF INVITATIONS FOR BIDS, OR REQUEST FOR PROPOSAL, EXCEPT THAT REFERENCED ADOPTED INDUSTRY DOCUMENTS SHALL GIVE THE DATE OF THE ISSUE ADOPTED
- FOR DESIGN FEATURE PURPOSES, THIS STANDARD TAKES PRECEDENCE OVER PROCUREMENT DOCUMENTS REFERENCED HEREIN

This military standard is approved for use by all Departments and Agencies of the Department of Defense. Selection for all new engineering and design applications and for repetitive use shall be made from this document.

P A Other Cost AR SH 99	INTERNATIONAL INTEREST	TITLE NUT, PLAIN, HEXAGON (MACHINE SCREW), CARBON STEEL, UNC-2B	MILITARY STANDARD
			MS51469
PROCUREMENT SPECIFICATION FF-N-836	SUPERSEDES:	PAGE	OF