

FED. SUP CLASS  
5305

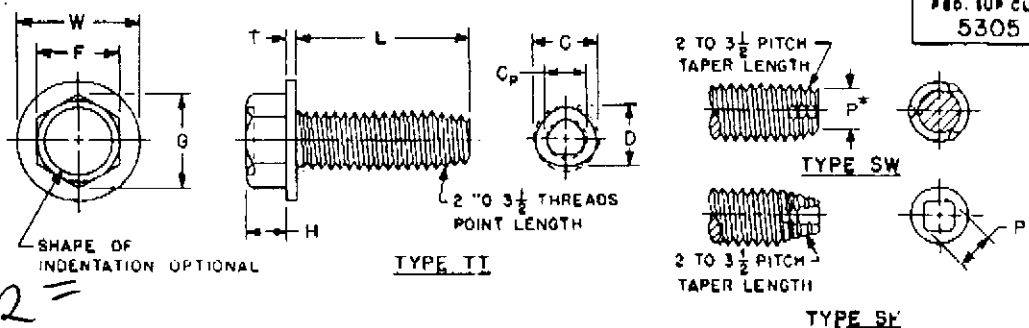

TRILOBULAR  
NO WAY

REVIEWER: AF, IS, MU, NS, OS, TD  
USER: AS, AT, MC, ME

NOMINAL SIZE		.118	.190	.250			
THREADS PER INCH		12	24	20			
F ACROSS FLATS	MAX	.250	.22	.375			
	MIN	.244	.21	.367			
C ACROSS CORNERS	MIN	.25	.345	.409			
H HEAD HEIGHT	MAX	.08	.120	.190			
	MIN	.08	.105	.177			
T WASHER THICKNESS	MAX	.025	.031	.050			
	MIN	.015	.019	.030			
W WASHER DIAMETER	MAX	.328	.414	.500			
	MIN	.302	.384	.470			
D DIAMETER	MAX	.141	.194	.2550			
	MIN	.135	.188	.2490			
C DIAMETER	MAX	.111	.151	.206			
AS CENTER	MAX	.118	.158	.2460			
	MIN	.119	.159	.2400			
POINT DIAMETER	MAX	.096	.1295	.180			
TYPE SW	MIN	.091	.1245	.175			
P POINT DIAMETER	MAX	.096	.147	.198			
TYPE SF	MIN	.095	.133	.181			
DASH NUMBER							
L LENGTH	TOL	CARBON STEEL	CRES STEEL	CARBON STEEL	CRES STEEL	CARBON STEEL	CRES STEEL
.750		1	C1				
.875		2	C2	12	C12		
1.000	-.000	3	C3	13	C13	23	C23
1.125	-.030	4	C4	14	C14	24	C24
1.250		5	C5	15	C15	25	C25
1.375				16	C16	26	C26
1.500	+1.000			17	C17	27	C27
1.750	-.050					28	C28
2.000						29	C29
						30	C30
						31	C31

REFERENCE ONLY  
DO NOT QUOTE

\* Before threading.

- NOTES:
- MATERIAL:** Carbon steel and corrosion-resisting steel (410) in accordance with procurement specification.
  - PROTECTIVE COATING:** Carbon steel-Cadmium plated in accordance with QQ-P-416, Type II, Class 3 or MIL-C-81562, Type II, Class 2. Corrosion-resisting steel-Passivated in accordance with QQ-P-35.
  - THREADS:** The threads shall be in accordance with the applicable requirements of the procurement specification.
  - DIMENSIONS:** All dimensions are in inches.
  - PART NUMBER:** The MS part number consists of the MS number, plus the dash number. Example: MS51869-1.
  - Referenced documents shall be of the issue in effect on date of invitations for bid.
  - For design feature purposes, this standard takes precedence over procurement documents referenced herein.
  - Type TT tri-lobular section is maintained throughout the full length of the screw.

This military standard is mandatory for use by all Departments and Agencies of the Department of Defense. Selection for all new engineering and design applications and for repetitive use shall be made from this document.

APPROVED 29 SEP 1972 REVISED

P.A. WC	TITLE	MILITARY STANDARD
Other Cust: SH 82	SCREW, TAPPING-HIGH PERFORMANCE, THREAD ROLLING, TYPES SF, SW AND TT, HEXAGON WASHER HEAD	MS51869
PROCUREMENT SPECIFICATION FX-S-107	SUPERSEDES: BCXAS.3 in part	SHEET 1 OF 1

DD FORM 672-1 (Continued)

PREVIOUS EDITIONS OF THIS FORM ARE OBSOLETE.