

MS9216 (ASG)

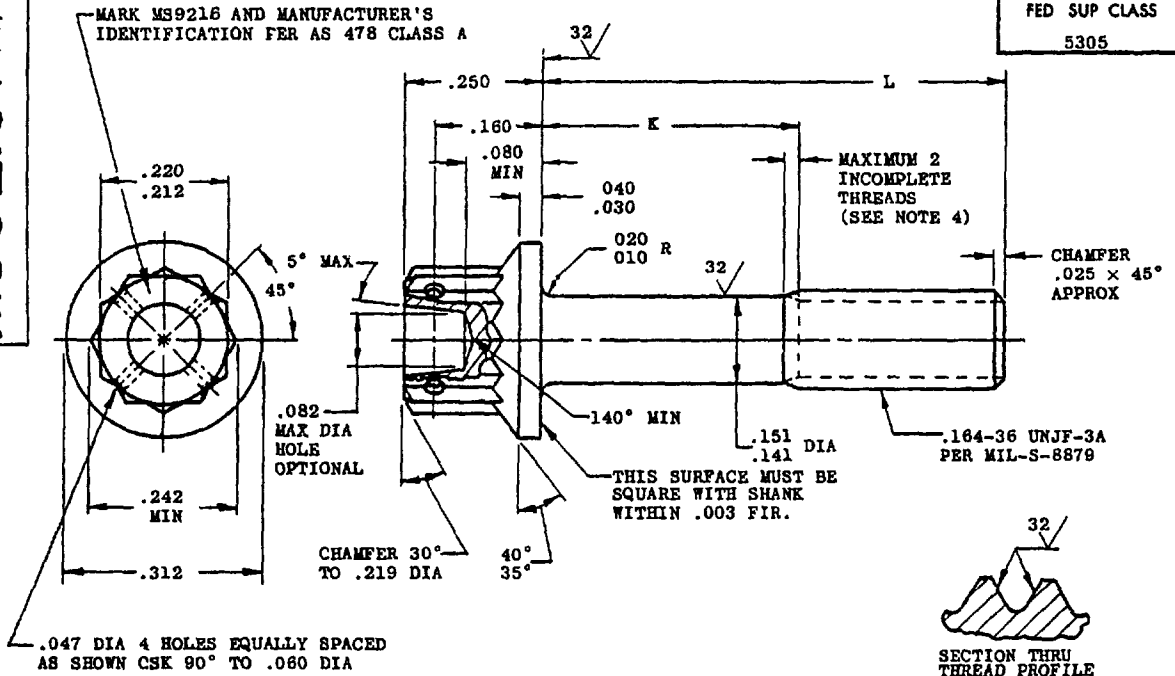

PART NO.	L	K	APPROX WEIGHT LB/100	PART NO.	L	K	APPROX WEIGHT LB/100
MS9216-03	.312	.062-.082	.451	MS9216-16	1.125	.487-.547	.847
MS9216-04	.375	.062-.082	.482	MS9216-17	1.188	.550-.610	.878
MS9216-05	.438	.062-.082	.513	MS9216-18	1.250	.612-.672	.908
MS9216-06	.500	.062-.082	.543	MS9216-19	1.312	.674-.734	.938
MS9216-07	.562	.062-.082	.573	MS9216-20	1.375	.737-.797	.969
MS9216-08	.625	.062-.082	.604	MS9216-21	1.438	.800-.860	.999
MS9216-09	.688	.062-.082	.634	MS9216-22	1.500	.862-.922	1.029
MS9216-10	.750	.112-.172	.664	MS9216-23	1.562	.924-.984	1.060
MS9216-11	.812	.174-.234	.695	MS9216-24	1.625	.987-1.047	1.090
MS9216-12	.875	.237-.297	.725	MS9216-25	1.688	1.050-1.110	1.121
MS9216-13	.938	.300-.360	.756	MS9216-26	1.750	1.112-1.172	1.151
MS9216-14	1.000	.362-.422	.786	MS9216-27	1.875	1.237-1.297	1.212
MS9216-15	1.062	.424-.484	.816	MS9216-28	2.000	1.362-1.422	1.273

Reviewers and Users
 USAF - ASD
 Navy - Wepps

This standard has been approved by the ASD (Department of the Air Force) and the Department of the Navy and is mandatory for use by that activity. All other military activities are required to employ this standard where suitable.

- SHANK SHALL BE STRAIGHT WITHIN .003 FIR. PER INCH OF SCREW LENGTH
- THE CONCENTRICITY OF THREAD PD IN RELATION TO THE SHANK SHALL BE WITHIN .006 FIR.
- THE CONCENTRICITY OF THE SHANK IN RELATION TO THE WASHER FACE DIAMETER AND DOUBLE HEXAGON OD SHALL BE WITHIN .010 FIR.
- INCOMPLETE THREADS NOT TO ENTER FILLET.
- MATERIAL: STEEL AMS 6304.
- HARDNESS: ROCKWELL C42-46.
- FINISH: DIFFUSED NICKEL-CADMIUM PLATE AMS 2416. DIMENSIONS SPECIFIED ARE AFTER PLATING. CONTACT POINTS PERMISSIBLE. PD MAY BE REDUCED .0012 MAXIMUM BEFORE PLATING.
- MANUFACTURING SPECIFICATION: AMS 7459. PARTS SUBJECT TO MAGNETIC PARTICLE INSPECTION PER AMS 2640 BEFORE PLATING.
- SURFACE ROUGHNESS: AS 291 UNLESS OTHERWISE SPECIFIED SURFACES TO BE 125 MICROINCHES EXCEPT UPSET HEAD.
- BREAK SHARP EDGES .003-.015 UNLESS OTHERWISE SPECIFIED.
- DIMENSIONS IN INCHES. UNLESS OTHERWISE SPECIFIED, TOLERANCES: LINEAR DIMENSIONS $\pm .010$, ANGULAR DIMENSIONS $\pm 5^\circ$.
- DO NOT USE UNASSIGNED PART NUMBERS.

AS & AMS ARE SOCIETY OF AUTOMOTIVE ENGINEERS, INC. PUBLICATIONS
 THIS STANDARD WAS DEVELOPED COOPERATIVELY WITH THE ENGINE AND PROPELLER UTILITY PARTS COMMITTEE OF THE SAE.

P.A. USAF - ASD Other Cust Navy - Wepps	TITLE SCREW, MACHINE - STEEL AMS 6304, DIFFUSED NICKEL-CADMIUM PLATE, DOUBLE HEXAGON EXTENDED WASHER HEAD, DRILLED, .164-36 UNJF-3A	MILITARY STANDARD MS9216 (ASG)
PROCUREMENT SPECIFICATION NONE	SUPERSEDES	SHEET 1 OF 1

REVISED 10 Dec 63
 APPROVED