

USER ACTIVITIES:

REVIEWER ACTIVITIES:
AIR FORCE-82
DLA-IS

DISTRIBUTION STATEMENT A. Approved for public release; distribution is unlimited.
This military standard is approved for use by all Departments and Agencies of the Department of Defense.
Selection for all new engineering and design applications and for repetitive use shall be made from this document when applicable.

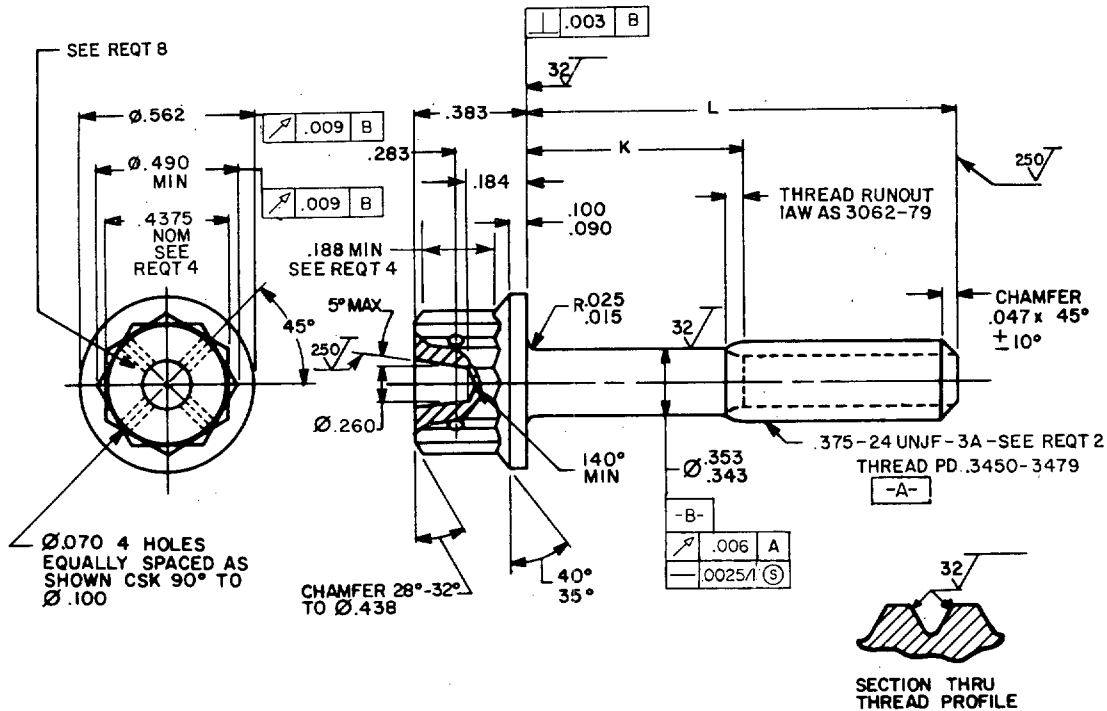

TABLE I. DASH NUMBERS AND DIMENSIONS

DASH NUMBER	L	K	APPROX WEIGHT LB/100	DASH NUMBER	L	K	APPROX WEIGHT LB/100	DASH NUMBER	L	K	APPROX WEIGHT LB/100
-04	.625	.088-.108	3.55	-22	1.750	.690-.750	6.72	-40	3.875	2.815-2.875	12.70
-05	.688	.088-.108	3.78	-23	1.812	.752-.812	6.89	-41	4.000	2.940-3.000	13.05
-06	.750	.088-.108	3.90	-24	1.875	.815-.875	7.07	-42	4.125	3.065-3.125	13.40
-07	.812	.088-.108	4.08	-25	2.000	.940-1.000	7.42	-43	4.250	3.190-3.250	13.76
-08	.875	.088-.108	4.25	-26	2.125	1.065-1.125	7.77	-44	4.375	3.315-3.375	14.11
-09	.938	.088-.108	4.43	-27	2.250	1.190-1.250	8.13	-45	4.500	3.440-3.500	14.46
-10	1.000	.088-.108	4.61	-28	2.375	1.315-1.375	8.48	-46	4.625	3.565-3.625	14.81
-11	1.062	.088-.108	4.78	-29	2.500	1.440-1.500	8.83	-47	4.750	3.690-3.750	15.16
-12	1.125	.088-.125	4.96	-30	2.625	1.565-1.625	9.18	-48	4.875	3.815-3.875	15.51
-13	1.188	.128-.188	5.14	-31	2.750	1.690-1.750	9.53	49	5.000	3.940-4.000	15.87
-14	1.250	.190-.250	5.31	-32	2.875	1.815-1.875	9.88	-50	5.125	4.065-4.125	16.22
-15	1.312	.252-.312	5.48	-33	3.000	1.940-2.000	10.24	-51	5.250	4.190-4.250	16.57
-16	1.375	.315-.375	5.66	-34	3.125	2.065-2.125	10.59	-52	5.375	4.315-4.375	16.92
-17	1.438	.378-.438	5.84	-35	3.250	2.190-2.250	10.94	-53	5.500	4.440-4.500	17.27
-18	1.500	.440-.500	6.01	-36	3.375	2.315-2.375	11.29	-54	5.625	4.565-4.625	17.62
-19	1.562	.502-.562	6.19	-37	3.500	2.440-2.500	11.64	55	5.750	4.690-4.750	17.98
-20	1.625	.565-.625	6.36	-38	3.625	2.565-2.625	11.99	-56	5.875	4.815-4.875	18.33
-21	1.688	.628-.688	6.54	-39	3.750	2.690-2.750	12.35	-57	6.000	4.940-5.000	18.68

(A) ENTIRE STANDARD REVISED

P. A. NAVY-AS Other Cust ARMY - AV AIR FORCE-99	INTERNATIONAL INTEREST	TITLE BOLT, MACHINE - DOUBLE HEXAGON, EXTENDED WASHER HEAD, DRILLED, CORROSION AND HEAT RESISTANT STEEL, .375-24 UNJF-3A	MILITARY STANDARD MS9708
PROCUREMENT SPECIFICATION AMS 7471	SUPERSEDES:	PAGE 1	OF 2

APPROVED 27 AUG 71 REVISED (A) 24 FEB 86

REQUIREMENTS:

1. MATERIAL: CORROSION AND HEAT RESISTANT STEEL IN ACCORDANCE WITH AMS 5708.
2. THREADS: THREADS IN ACCORDANCE WITH MIL-S-8879. INCOMPLETE THREADS NOT TO ENTER FILLET.
3. DIMENSIONING AND TOLERANCING: DIMENSIONING AND TOLERANCING SHALL BE IN ACCORDANCE WITH ANSI Y14.5M.
4. WRENCHING CONFIGURATION: WRENCHING CONFIGURATION IN ACCORDANCE WITH AS 870.
5. SURFACE TEXTURE: SURFACE TEXTURE, UNLESS OTHERWISE SPECIFIED, SHALL BE 125 MICROINCHES EXCEPT UPSET HEAD IN ACCORDANCE WITH ANSI B46.1.
6. FLUORESCENT PENETRANT INSPECTION: FLUORESCENT PENETRANT INSPECTION SHALL BE IN ACCORDANCE WITH AMS 2645-83.
7. HEAD TO SHANK FILLET: HEAD TO SHANK FILLET SHALL BE COLD ROLLED AFTER HEAT TREATMENT TO REMOVE ALL VISUAL EVIDENCE OF GRINDING OR TOOL MARKS EXCEPT DASH NUMBER SIZES -14 AND SMALLER.
8. MARKING: MARK PART NUMBER AND MANUFACTURER'S IDENTIFICATION IN ACCORDANCE WITH AS 478-79, CLASS A.
9. TOLERANCE: UNLESS OTHERWISE SPECIFIED, TOLERANCES SHALL BE FOR LINEAR DIMENSIONS $\pm .010$, ANGULAR DIMENSIONS $\pm 5^\circ$.
10. EDGES: BREAK SHARP EDGES .003-.015 UNLESS OTHERWISE SPECIFIED.
11. PART NUMBER: THE PART NUMBER SHALL CONSIST OF THE BASIC MS NUMBER FOLLOWED BY A DASH NUMBER FROM TABLE I.

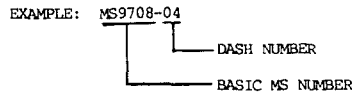

MS9708-04 INDICATES: BOLT, MACHINE - DOUBLE HEXAGON EXTENDED WASHER HEAD, DRILLED .375-24 UNJF-3A, LENGTH .625

NOTES:

1. ALL DIMENSIONS ARE IN INCHES.
2. DO NOT USE UNASSIGNED PART NUMBERS.
3. IN THE EVENT OF A CONFLICT BETWEEN THE TEXT OF THIS STANDARD AND THE REFERENCES CITED HEREIN, THE TEXT OF THIS STANDARD SHALL TAKE PRECEDENCE.
4. REFERENCED GOVERNMENT (OR NONGOVERNMENT) DOCUMENTS OF THE ISSUE LISTED IN THAT ISSUE OF THE DEPARTMENT OF DEFENSE INDEX OF SPECIFICATIONS AND STANDARDS (DODISS) SPECIFIED IN THE SOLICITATION FORM A PART OF THIS STANDARD TO THE EXTENT SPECIFIED HEREIN.
5. THIS STANDARD WAS DEVELOPED COOPERATIVELY WITH THE SAE AEROSPACE PROPULSION DIVISION.
6. AS AND AMS ARE SAE PUBLICATIONS.

USER ACTIVITIES:

REVIEWER ACTIVITIES:
AIR FORCE-82
DLA-1S

This military standard is approved for use by all Departments and Agencies of the Department of Defense. Selection for all new engineering and design applications and for repetitive use shall be made from this document when applicable.

APPROVED 27 AUG 71 REVISED (A) FOR CHANGES SEE PAGE 1 AND 2

P. A. NAVY-AS Other Cust ARMY - AV AIR FORCE-99	INTERNATIONAL INTEREST	TITLE BOLT, MACHINE-DOUBLE HEXAGON, EXTENDED WASHER HEAD, DRILLED, CORROSION AND HEAT RESISTANT STEEL, .375-24 UNJF-3A	MILITARY STANDARD
			MS9708
PROCUREMENT SPECIFICATION AMS 7471	SUPERSEDES:	PAGE 2	OF 2