

# INTERNATIONAL STANDARD

**ISO**  
**14580**

First edition  
2001-09-01

---

---

## **Hexalobular socket cheese head screws**

*Vis à métaux à tête cylindrique basse à six lobes internes*



Reference number  
ISO 14580:2001(E)

© ISO 2001

**PDF disclaimer**

This PDF file may contain embedded typefaces. In accordance with Adobe's licensing policy, this file may be printed or viewed but shall not be edited unless the typefaces which are embedded are licensed to and installed on the computer performing the editing. In downloading this file, parties accept therein the responsibility of not infringing Adobe's licensing policy. The ISO Central Secretariat accepts no liability in this area.

Adobe is a trademark of Adobe Systems Incorporated.

Details of the software products used to create this PDF file can be found in the General Info relative to the file; the PDF-creation parameters were optimized for printing. Every care has been taken to ensure that the file is suitable for use by ISO member bodies. In the unlikely event that a problem relating to it is found, please inform the Central Secretariat at the address given below.

© ISO 2001

All rights reserved. Unless otherwise specified, no part of this publication may be reproduced or utilized in any form or by any means, electronic or mechanical, including photocopying and microfilm, without permission in writing from either ISO at the address below or ISO's member body in the country of the requester.

ISO copyright office  
Case postale 56 • CH-1211 Geneva 20  
Tel. + 41 22 749 01 11  
Fax + 41 22 749 09 47  
E-mail [copyright@iso.ch](mailto:copyright@iso.ch)  
Web [www.iso.ch](http://www.iso.ch)

Printed in Switzerland

## Foreword

ISO (the International Organization for Standardization) is a worldwide federation of national standards bodies (ISO member bodies). The work of preparing International Standards is normally carried out through ISO technical committees. Each member body interested in a subject for which a technical committee has been established has the right to be represented on that committee. International organizations, governmental and non-governmental, in liaison with ISO, also take part in the work. ISO collaborates closely with the International Electrotechnical Commission (IEC) on all matters of electrotechnical standardization.

International Standards are drafted in accordance with the rules given in the ISO/IEC Directives, Part 3.

Draft International Standards adopted by the technical committees are circulated to the member bodies for voting. Publication as an International Standard requires approval by at least 75 % of the member bodies casting a vote.

Attention is drawn to the possibility that some of the elements of this International Standard may be the subject of patent rights. ISO shall not be held responsible for identifying any or all such patent rights.

International Standard ISO 14580 was prepared by Technical Committee ISO/TC 2, *Fasteners*.

This page intentionally left blank

# Hexalobular socket cheese head screws

## 1 Scope

This International Standard specifies the characteristics of hexalobular socket cheese head screws in product grades A and with thread sizes from M2 up to and including M10.

If, in special cases, specifications other than those listed in this International Standard are required, they should be selected from existing International Standards, for example ISO 261, ISO 888, ISO 898-1, ISO 965-2, ISO 3506-1, ISO 4759-1.

## 2 Normative references

The following normative documents contain provisions which, through reference in this text, constitute provisions of this International Standard. For dated references, subsequent amendments to, or revisions of, any of these publications do not apply. However, parties to agreements based on this International Standard are encouraged to investigate the possibility of applying the most recent editions of the normative documents indicated below. For undated references, the latest edition of the normative document referred to applies. Members of ISO and IEC maintain registers of currently valid International Standards.

ISO 225:1983, *Fasteners — Bolts, screws, studs and nuts — Symbols and designations of dimensions*

ISO 261:1998, *ISO general-purpose metric screw threads — General plan*

ISO 888:1976, *Bolts, screws and studs — Nominal lengths, and thread lengths for general purpose bolts*

ISO 898-1:1999, *Mechanical properties of fasteners made of carbon steel and alloy steel — Part 1: Bolts, screws and studs*

ISO 965-2:1998, *ISO general purpose metric screw threads — Tolerances — Part 2: Limits of sizes for general purpose external and internal screw threads — Medium quality*

ISO 1207:1992, *Slotted cheese head screws — Product grade A*

ISO 3269:2000, *Fasteners — Acceptance inspection*

ISO 3506-1:1997, *Mechanical properties of corrosion-resistant stainless-steel fasteners — Part 1: Bolts, screws and studs*

ISO 4042:1999, *Fasteners — Electroplated coatings*

ISO 4759-1:2000, *Tolerances for fasteners — Part 1: Bolts, screws, studs and nuts — Product grades A, B and C*

ISO 6157-1:1988, *Fasteners — Surface discontinuities — Part 1: Bolts, screws and studs for general requirements*

ISO 8839:1986, *Mechanical properties of fasteners — Bolts, screws, studs and nuts made of non-ferrous metals*

ISO 8992:1986, *Fasteners — General requirements for bolts, screws, studs and nuts*

ISO 10664:1999, *Hexalobular internal driving feature for bolts and screws*

ISO 10683:2000, *Fasteners — Non-electrolytically applied zinc flake coatings*

### 3 Dimensions

See Figure 1 and Table 1.

Symbols and designations of dimensions, except dimension *A*, are specified in ISO 225.

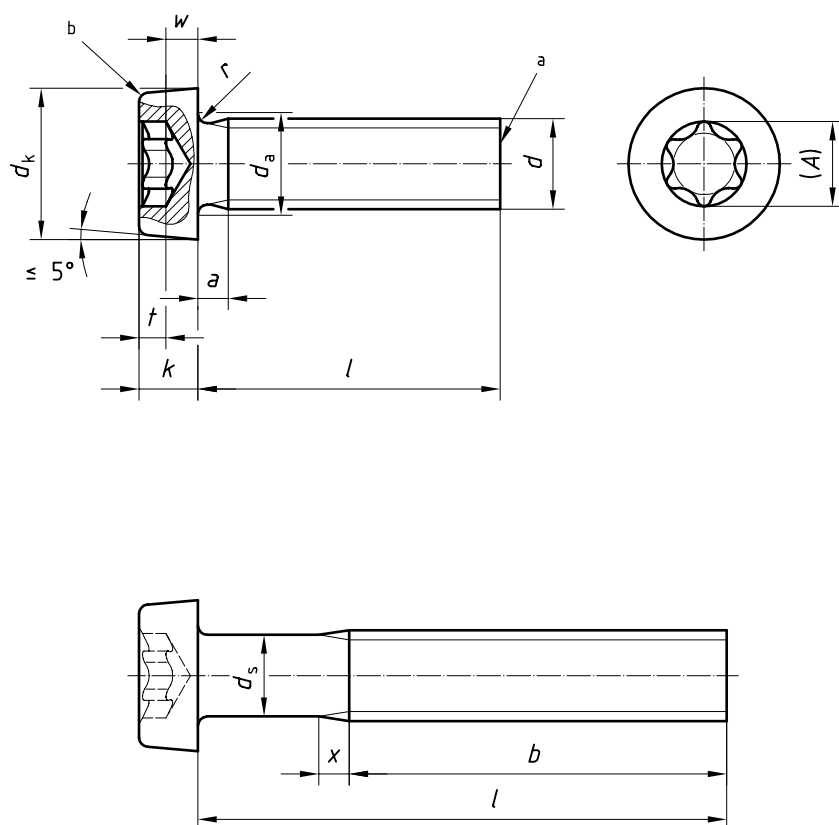

NOTE Shank diameter  $d_s$  is approximately equal to pitch diameter or equal to major thread diameter.

- a As-rolled end
- b Edge may be rounded or flat

Figure 1

Table 1 — Dimensions

Dimensions in millimetres

Thread <i>d</i>			M2	M2,5	M3	(M3,5) <sup>a</sup>	M4	M5	M6	M8	M10		
<i>p</i> <sup>b</sup>			0,4	0,45	0,5	0,6	0,7	0,8	1	1,25	1,5		
<i>a</i> max.			0,8	0,9	1	1,2	1,4	1,6	2	2,5	3		
<i>b</i> min.			25	25	25	38	38	38	38	38	38		
<i>d<sub>k</sub></i>	nom. = max.		3,80	4,50	5,50	6,00	7,00	8,50	10,00	13,00	16,00		
	min.		3,62	4,32	5,32	5,82	6,78	8,28	9,78	12,73	15,73		
<i>d<sub>a</sub></i> max.			2,6	3,1	3,6	4,1	4,7	5,7	6,8	9,2	11,2		
<i>k<sup>c</sup></i>	nom. = max.		1,55	1,85	2,40	2,60	3,10	3,65	4,40	5,80	6,90		
	min.		1,41	1,71	2,26	2,46	2,92	3,47	4,10	5,50	6,54		
<i>r</i> max.			0,1	0,1	0,1	0,1	0,2	0,2	0,25	0,4	0,4		
<i>w</i> min.			0,5	0,7	0,75	1,0	1,1	1,3	1,6	2	2,4		
<i>x</i> max.			1,0	1,1	1,25	1,50	1,75	2,0	2,5	3,2	3,8		
Hexalobular socket			Socket No.	<b>6</b>	<b>8</b>	<b>10</b>	<b>15</b>	<b>20</b>	<b>25</b>	<b>30</b>	<b>45</b>	<b>50</b>	
			<i>A</i> ref.	1,75	2,4	2,8	3,35	3,95	4,5	5,6	7,95	8,95	
			<i>t</i>	max.	0,84	0,91	1,27	1,33	1,66	1,91	2,29	3,05	3,43
				min.	0,71	0,78	1,01	1,07	1,27	1,52	1,90	2,66	3,04
nom. <sup>a</sup>			Approximate mass of carbon steel screws, in kilograms per 1 000 pieces ( $\rho = 7,85 \text{ kg/dm}^3$ )										
<i>l<sup>d</sup></i> min.													
max.													
<b>3</b>	2,8	3,2	0,160	0,272									
<b>4</b>	3,76	4,24	0,179	0,302	0,515								
<b>5</b>	4,76	5,24	0,198	0,332	0,560	0,786	1,09						
<b>6</b>	5,76	6,24	0,217	0,362	0,604	0,845	1,17	2,06					
<b>8</b>	7,71	8,29	0,254	0,422	0,692	0,966	1,33	2,30	3,56				
<b>10</b>	9,71	10,29	0,291	0,482	0,780	1,08	1,47	2,55	3,92	7,85			
<b>12</b>	11,65	12,35	0,329	0,542	0,868	1,20	1,63	2,80	4,27	8,49	14,6		
<b>(14)</b>	13,65	14,35	0,365	0,602	0,956	1,32	1,79	3,05	4,62	9,13	15,6		
<b>16</b>	15,65	16,35	0,402	0,662	1,04	1,44	1,95	3,30	4,98	9,77	16,6		
<b>20</b>	19,58	20,42	0,478	0,782	1,22	1,68	2,25	3,78	5,69	11,0	18,6		
<b>25</b>	24,58	25,42		0,932	1,44	1,98	2,64	4,40	6,56	12,6	21,1		
<b>30</b>	29,58	30,42			1,66	2,28	3,02	5,02	7,45	14,2	23,6		
<b>35</b>	34,5	35,5				2,57	3,41	5,62	8,25	15,8	26,1		
<b>40</b>	39,5	40,5					3,80	6,25	9,20	17,4	28,6		
<b>45</b>	44,5	45,5						6,88	10,0	18,9	31,1		
<b>50</b>	49,5	50,5						7,50	10,9	20,6	33,6		
<b>(55)</b>	54,4	55,6							11,8	22,1	36,1		
<b>60</b>	59,4	60,6							12,7	23,7	38,6		
<b>(65)</b>	64,4	65,6								25,2	41,1		
<b>70</b>	69,4	70,6								26,8	43,6		
<b>(75)</b>	74,4	75,6								28,3	46,1		
<b>80</b>	79,4	80,6								29,8	48,6		
NOTE Commercial lengths are the ones between the bold stepped lines													
<sup>a</sup> Sizes in parentheses should be avoided if possible.													
<sup>b</sup> <i>P</i> pitch of the thread.													
<sup>c</sup> The head height is increased as against the screws in accordance with ISO 1207 in order to improve the head strength.													
<sup>d</sup> Screws with nominal lengths above the dashed stepped line are threaded up to the head ( $b = l - a$ ). See ISO 888.													

## 4 Specifications and reference International Standards

See Table 2.

**Table 2 — Specifications and reference International Standards**

Material		Steel	Stainless steel	Non-ferrous metal
<b>General requirements</b>	International Standard	ISO 8992		
	Tolerance	6g		
<b>Thread</b>	International Standards	ISO 261, ISO 965-2		
	Property class	4.8 5.8	A2-50, A2-70 A3-50, A3-70	As agreed
<b>Mechanical properties</b>	International Standards	ISO 898-1	ISO 3506-1	ISO 8839
	Product grade	A		
<b>Tolerances</b>	International Standard	ISO 4759-1		
	International Standard	ISO 10664		
<b>Hexalobular socket</b>	International Standard	ISO 10664		
	<b>Finish</b>	As processed	Plain	Plain
Requirements for electroplating are covered in ISO 4042. Requirements for non-electrolytically applied zinc flake coatings are covered in ISO 10683.		—	Requirements for electroplating are covered in ISO 4042.	
<b>Surface discontinuities</b>	Limits for surface discontinuities are covered in ISO 6157-1.	—	—	
	<b>Acceptability</b>	For acceptance procedure, see ISO 3269.		

## 5 Designation

**EXAMPLE** A hexalobular socket cheese head screw with thread M5, nominal length  $l = 20$  mm and property class 4.8 is designated as follows:

**Hexalobular socket cheese head screw ISO 14580 - M5 × 20 - 4.8**